



PRECISION FARMING

C501





ISO 9001:2000 certified ARAG quality

With further ISO 9001:2000 certification, ARAG highlights the concepts of “customer satisfaction” and “ongoing improvement”, which inspire our work, to guarantee maximum reliability of products and constant, quality support for our customers.



Symbols



Recommended for use on crop sprayers



Recommended for use on orchard sprayers



Recommended for use on low-volume machines



Recommended for multi-row sprayers



Integrated GPS System or ready for satellite connection



New items



New items

ARAG is delighted to present its brand new catalogue - PRECISION FARMING, with a complete range of high-tech products specifically designed for those whose work requirements focus on outstandingly high levels of quality and precision.

In ARAG's mind, Precision Farming means supplying those who work for, and with, the land, with the ideal tools with which to optimize their activities, and achieve excellence with regard to timeframes, costs and performance.

ARAG was able to focus on creating and developing the Precision Farming range because it prides itself in its ability to establish direct contact with its customers, listening to their problems, their requirements and it has used this information to turn Precision Farming into action and not just words so that you can actually see the benefits in your everyday work.

The PRECISION FARMING range presents products installed with some of the most advanced electronic and satellite technologies available in the world today; our aim is to provide users with tools they can use to work better, more accurately, saving precious time, optimizing the use of pesticides, paying attention to the needs of man but also the environment. We want to assure and prove to our Customers that the use of these machines to map the land, to identify the areas to be sprayed, to manage spraying booms, and monitor every part of the system will guarantee high precision results in the shortest time possible.

ARAG can respond and provide solutions to every specific need, every possible requirement, in every corner of the world, and in every spoken language. An extensive and comprehensive range of products designed for man and nature, described in just two words: PRECISION FARMING.

Because these two words are not simply 'words', but rather the image of your everyday work and commitment.



Job Computer ISOBUS GCS3200	3
BRAVO 400 computer	6
Alfa 310 Monitor for seeder	13
SKIPPER satellite navigator	19
SKIPPER LT satellite navigator	20
SIRIO LT GPS guidance system	21
BRAVO 300S computer	22
BRAVO 300S RCU computer - Crop, multi-row and sequential sprayer	24
BRAVO 300S computer - Direct connection to crop, multi-row and sequential sprayer	27
BRAVO 300S computer - Direct connection to orchard sprayer	30
BRAVO 180 computer - Crop and multi-row sprayer	32
BRAVO 180 computer - Orchard sprayer	35
BRAVO 130 computer	36
BRAVO 140 computer	37
BRAVO 120 monitor	40
BRAVO 110 monitor - Crop sprayer	42
BRAVO 110 monitor - Orchard sprayer	43
Digiblock2 multifunction display	44
ORION VISUAL FLOW electromagnetic flow-meters	46
ORION Electromagnetic flow-meters	47
Vision system	48
BRAVO DSB simulator	49
Accessories for BRAVO computer	50
Skipper navigator manager	52
Spare parts	53

▶ ISOBUS Communication System

ISOBUS is the international standardised system set by ISO11783 that defines the information exchange protocols for farming machines. Thanks to this standard protocol, all the electronic devices available on a farming machine, regardless of their manufacturer, can exchange information and communicate with each other.

It will then be possible to use just one monitor in the cabin to view data and output controls to any connected device. This allows for improved tractor cabin ergonomic design, due to the deletion of the many control units connected to each single device, and ensures time-efficient servicing.

Principle of operation

ISOBUS system is equipped with a *Tractor ECU* (TECU) that controls communication among the control units connected on the bus and makes available all tractor operating information. *The Virtual Terminal* (VT) is installed inside tractor's cabin and it is used to view, control and set all machine parameters, while at the rear is a standard socket that allows user to power and take communication signals to any equipment the user decides to connect.

Such equipment will fit a suitable connector allowing the ISOBUS JOB COMPUTER control unit to output information to the Virtual Terminal and receive operator's controls.

The Virtual Terminal keyboard is not suitable for some kind of equipment, so the standard has provided for connection of further control devices (push-button boards, joysticks, etc.) to the ISOBUS network in order to help machine control. These control devices are called *Auxiliary Inputs*.



- Up to 13 (water) sections
- Up to 9 hydraulic controls
- Complies with ISOBUS standard (ISO 11783)



CODE Auxiliary input	CODE Job Computer	Ways	Hydraulic functions
468 22501	468 32501	5	0
468 22511	468 32511	5	7
468 22701	468 32701	7	0
468 22711	468 32711	7	7
468 22721	468 32721	7	9
468 22D01	468 32D01	8÷13	0

Main features

- Nozzle wear check via simultaneous reading of flow rate and pressure values
- Graphic indicator for tank level
- Displayable data: instant spray rate, supplied spray rate, speed, pressure, flow rate, distributed amount, tank level, rotation speed, sprayed surface, spraying time, productivity, date and time, covered distance
- Automatic spraying stop if pressure value drops under preset min. value so that nozzles work within their operating range.
- Automatic closing of main valve under min. preset speed.
- Alarms for: preset spray rate not reached, tank low level, min./max. nozzle working pressure, min./max. rotation speed, flow-meter out of operating range, excessively worn-out nozzles
- Automatic switch to pressure sensor if the flow-meter works outside preset limits.
- Temporary increase and reduction of distributed fluid.
- Storage of 20 combinations of spray rate/nozzle to be activated before starting spraying.
- Automatic adjustment via flow rate and/or pressure detection (by flow-meter or pressure sensor)

Technical features

- Connection to tractor by ISOBUS standard connector
- Inputs for signals of: flow rate, speed, pressure, filling flow rate, revolution counter, Pump Protector
- Outputs to control up to 7 boom sections (13 in the sequential version), control valve, main valve and foam marker
- Outputs to control up 9 hydraulic functions and drain valve
- Selectable language: Italian, English, Spanish, French, Portuguese and German.
- Selectable units of measurement: International (ha, km/h) or US (Ac, mph)
- Power supply: 12Vdc.

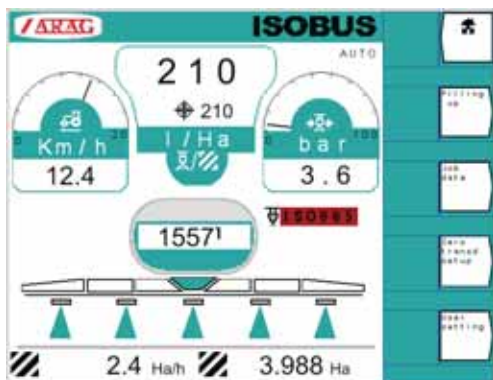

The spraying page displays all relevant data for each application type as the system allows the user to set type and data position. The most important data are highlighted in order to be more visible by means of colour and size.

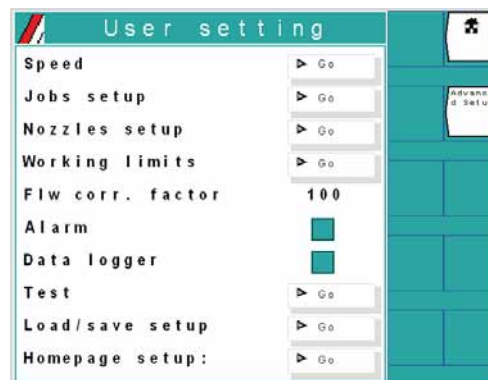

User-friendliness is ensured by menu in various languages that clarify any ambiguity that might be due to the use of symbols only.

▶ ISOBUS Communication System

INSTALLATION DIAGRAM AND PACKAGE CONTENT

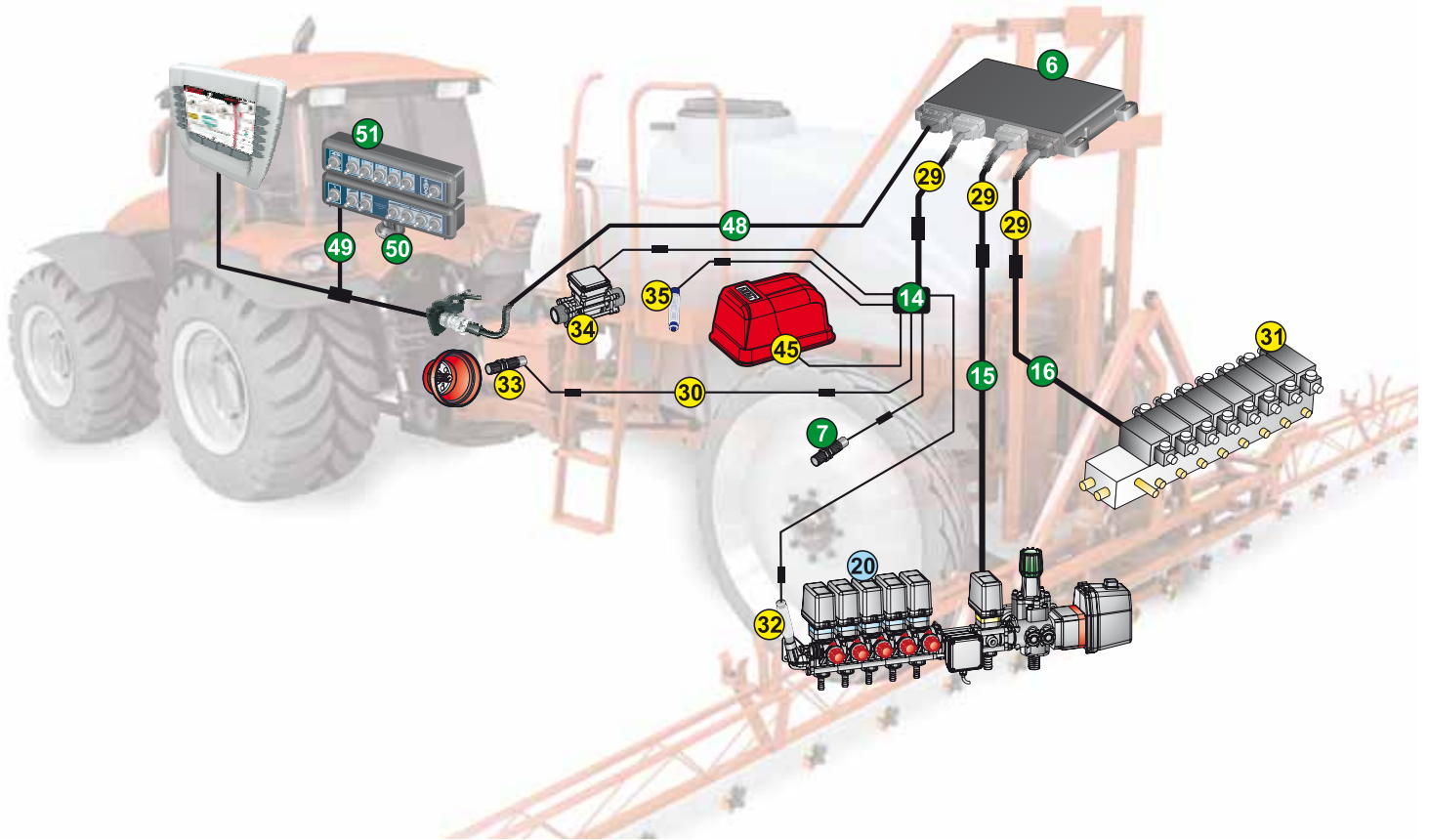

The package includes:

6	Remote control unit
7	Inductive speed sensor with 5 m cable
14	Sensor cable - 3 m + power cable - 5 m
15	Water valve cable - 3 m
16	Oil hydraulic valve cable - 3 m
48	ISOBUS main cable - 10 m
49	AUXILIARY INPUT cable - 1 m
50	Suction cup support
51	Auxiliary Input
	User's and quick guide and quick reference guide

To be order separately:

20	Control unit
----	--------------

Accessories:

		CODE
29	'Black' extension cable - 3 m	46732000.110
29	'Grey' extension cable - 3 m	46732000.120
	Sensor extension cable - 3 m	466553.220
30	Sensor extension cable - 5 m	466553.230
31	Hydraulic control unit	
32	Pressure transducer	466112.200 466112.500
33	RPM sensor	467100.100 467100.086
34	Filling flow-meter	
35	Pump Protector	4664000.100
45	Foam marker	520 005C 520 0052C



BRAVO 400 is the fruit of a long-term field experience and steady improvement of electronic satellite products. BRAVO 400 is a market leading computer for crop sprayers featuring special functions for big farming machines, large fields and demanding users. Its wide and bright colour display, integrated navigator and its ability to control outer cameras are only some of the outstanding BRAVO 400 features, which will surely impress even users already familiar with the electronic aspects of farming machines.



Crop sprayer version		
CODE	Ways	Hydraulic functions
467 42501	5	0
467 42701	7	0
467 42511	5	7
467 42711	7	7
467 42721	7	9

Version for seleJET		
CODE	Ways	Hydraulic functions
467 47501	5	0
467 47701	7	0
467 47511	5	7
467 47711	7	7
467 47721	7	9

SELEJET nozzle holders are available in ARAG main catalogue ARAG C106

Sequential version	
CODE	Ways
467 42D01	8÷13

The sequential computer works only if connected to 3-wire valves. When ordering a single valve please add a T at the end of the part number concerned or order a control unit.



MAIN FEATURES



Air-operated control unit on page 50

The need for higher spray rate during a single treatment, variable spray rate and for nozzles which can cover resulting big variations led us to develop a system able to automatically select either the right nozzle or the right nozzle combination depending on scheduled job. An air-operated unit and nozzle holders (see ARAG C106 main catalogue) complete the system for perfect control of all required operations.



A driving system should be positioned where it can be perfectly seen, that is in front of the operator so that he/she can watch both monitor and field while driving. Section and hydraulic boom controls should be instead positioned on operator's side, within user's reach. This is why BRAVO 400 can be disassembled into two separate units to be ergonomically fitted into the cabin. A suction cup support is also available so that keyboards can be comfortably fitted within operator's reach.



SD memory card serves as connection unit between BRAVO 400 and other devices. This memory card allows several operations for easier computer and data use. BRAVO 400 can both import direction maps from the card and export completed job data, regularly saved while spraying. Its installation onto the farming machine and remote technical assistance are very easy as computer settings can be copied onto identical machines or sent to Technical Assistance via e-mail to correct configuration errors. Software updates can be downloaded directly from ARAG website. A watertight cover protects the memory card from dust and water splashes.



The Remote Control Unit (RCU) communicates with the computer through a single cable having CANBUS protocol. RCU ensures an easier installation especially in towed machines and the control of hydraulic units moving the booms. Its special slide connectors and its watertight body allow a safe installation even in points splashed with water or subject to weather conditions.

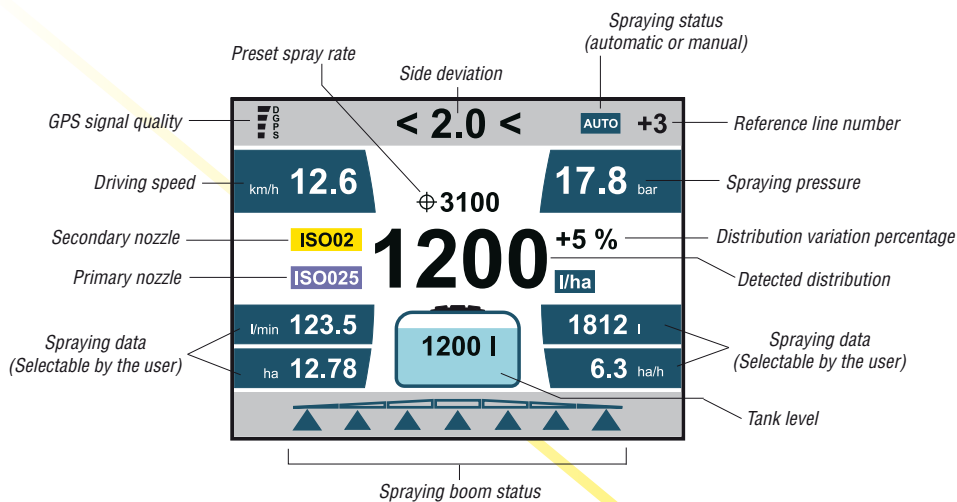

Everything under control

The spraying page displays all data for each application type as the system not only allows the user to set type but also data position. Main driving information and section status are displayed at any time so that reference track can be properly followed.

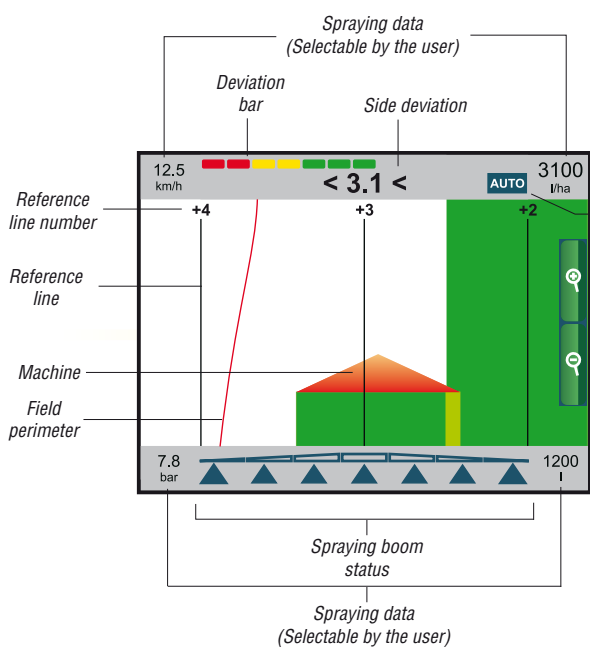

Section closing and automatic adjustment

While driving only useful information are displayed onto the navigation page so that most monitor area is left for correct track display. Bravo 400 automatically adjusts spray rate and closes sections so not to spray the same areas twice, thus increasing spraying accuracy. Depending on required results and spraying type, max. allowed overlapping percentage can be set, above which bar sections are closed.

All that you need to know

Detailed information on completed job is available so to have a global overview. Each single piece of information or the whole report can be zeroed by pressing the relevant function keys.

Job data		
Covered Area:	18.12	ha
Applied quantity:	2003	l
Application time:	05:25	hh:mm
Productivity:	3.6	ha/h
Target rate:	180	l/ha
Rate applied:	180.0	l/ha
Nozzle A:	ISO02	
Nozzle B:	ISO025	
Starting date:	06/02/08	
Starting time:	18:12	

OPERATION

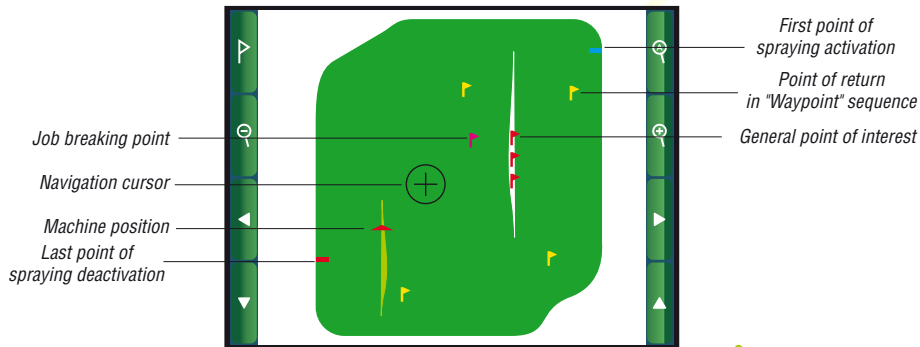

Safe driving

Report window allows the user to magnify the image so to display the completed job in details. More than one point can be marked which the user can later return to for checking and restarting the job. Bravo 400 will give all instructions to sequentially reach all previously marked points from the driving page.

Total job control

Up to two cameras can be connected to BRAVO 400 to check hidden areas (for ex. while driving backwards). Cameras also shoot digital pictures to document special working situations. The user can select either full screen or reduced image in case main spraying data need to be displayed along with the very image.

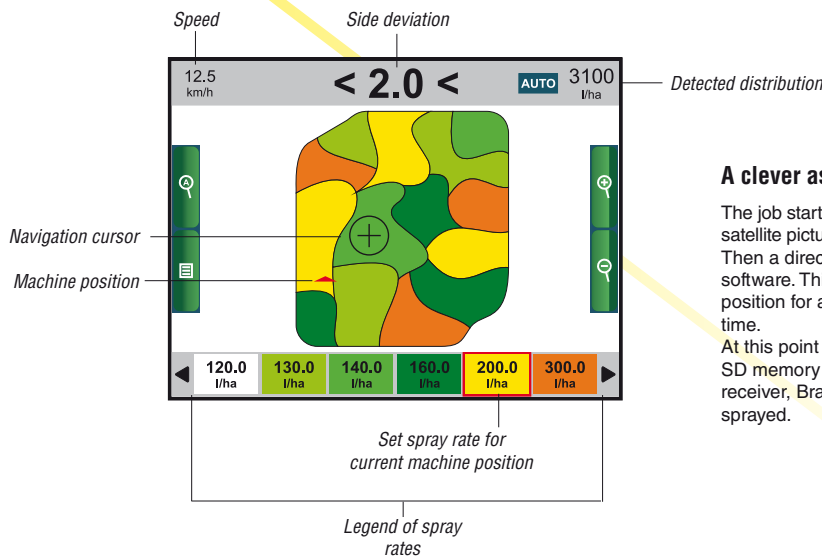
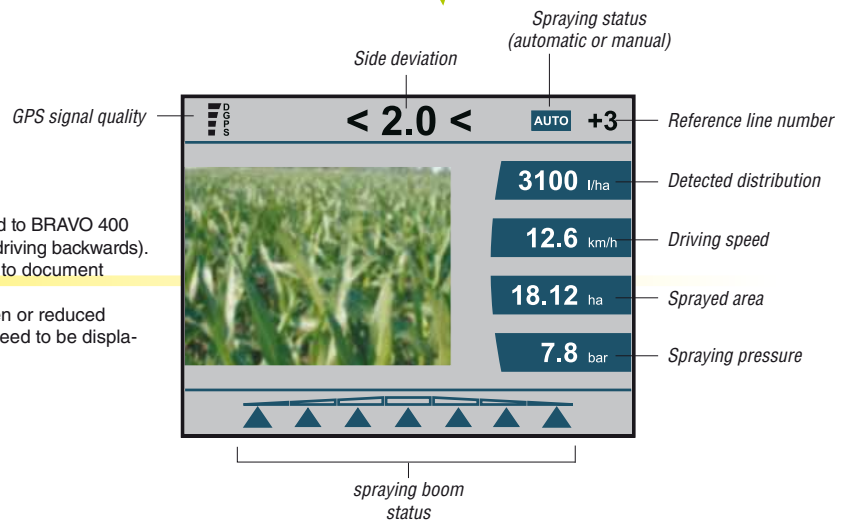

A clever assistant

The job starts with an accurate field data collection (chemical analysis, satellite picture, analysis of field yield during previous years and so on). Then a direction map is created by installed analysis and simulation software. This map indicates the recommended spray rate for each position for an optimal yield at minimum costs and minimum working time. At this point the direction map can be uploaded onto Bravo 400 via SD memory card. According to the position detected by the GPS receiver, Bravo will use the spray rate specified for the area being sprayed.



Main features

- Automatic section closing when an adjacent area is being sprayed twice.
- Variable spray rate control including direction map zooming in and out.
- Full-screen display or reduced size display -along with spraying and driving information- of images from two cameras.
- SD memory card for completed job storage, settings storage/loading and software updates.
- Automatic brightness and colour control via integrated sensor.
- Special key to quickly display the following pages from the main driving data page: spraying control, total completed job display, cameras, job data and variable rate application.
- User's set data to be displayed on driving and spray control pages.
- Displayable data: side deviation, track number, calculated surface, field perimeter, GPS signal quality, direction, instant spray rate, supplied spray rate, speed, pressure, flow rate, distributed amount, tank level, rotation speed, covered area, spraying time, productivity, date, time, covered distance

Driving features

- Driving mode: "Parallel", "Curved parallel" and "Contour".
- Calculation of field area and perimeter
- Buzzer for correct steering time to properly centre next track depending on preset steering radius.
- Realignment function for lined crops such as maize, cane and so on.
- Display of number of lines, distance and direction to return to the job breaking point.
- Alarms for: spraying overlapping, poor GPS accuracy, no DGPS signal
- Completed job overview, zooming in or out and storage of unsprayed areas to allow job completion.
- Displayable GPS data: latitude, longitude, altitude, number of satellites, index of signal degradation (HDOP), last DGPS correction time and availability.
- Automatic correction of position error due to machine inclination via ATD sensor (to be ordered separately).
- Driving page can be zoomed in or out according to operator's needs.
- Storage and display of points of interests.
- 2D or 3D driving indications.

Spraying features

- Automatic nozzle selection while spraying
- Nozzle wear check via simultaneous reading of flow rate and pressure values
- Automatic spraying stop if pressure value drops under preset min. value so that nozzles work within their operating range.
- Automatic closing of main valve under min. preset speed.
- Nozzle wear check via simultaneous reading of flow rate and pressure values
- Alarms for: min./max. nozzle operating pressure, min./max. rotation speed, flow-meter out of operating range, excessively worn-out nozzles
- Automatic switch to pressure sensor if the flow-meter works outside preset limits.
- Temporary increase and reduction of distributed fluid.
- Storage of 20 combinations of spray rate/nozzle to be activated before starting spraying.
- Automatic adjustment via flow rate and/or pressure detection (by flow-meter or pressure sensor)

GPS receiver features

- Free WAAS/EGNOS/MSAS differential correction (USA, Europe and Japan only)
- Illuminated status indicators for: valid GPS signal, valid differential correction and power on
- Threaded or magnetic support

Technical features

- Integrated Secure Digital (SD) memory card reader
- No. 2 composite video inputs for cameras
- Monitor and push-button boards for section and hydraulic controls can be installed separately
- Input for main valve outer control
- Separate RCU
- RS232 serial port for GPS connection
- Internal clock, self-powered and automatically set via GPS.
- Inputs for signals of: flow rate, speed, pressure, filling flow rate, revolution counter, Pump Protector.
- Outputs to control up to 7 boom sections (13 in the sequential version), control valve and main valve
- Outputs to control up to 9 hydraulic functions and drain valve
- Selectable language: Italian, English, Spanish, French, Portuguese, German, Polish, Russian and Czech.
- Selectable units of measurement: International (ha, km/h) or US (Ac, mph)
- 5.7" TFT graphic colour display.
- Power supply: 12Vdc.





INSTALLATION

INSTALLATION DIAGRAM AND PACKAGE CONTENT

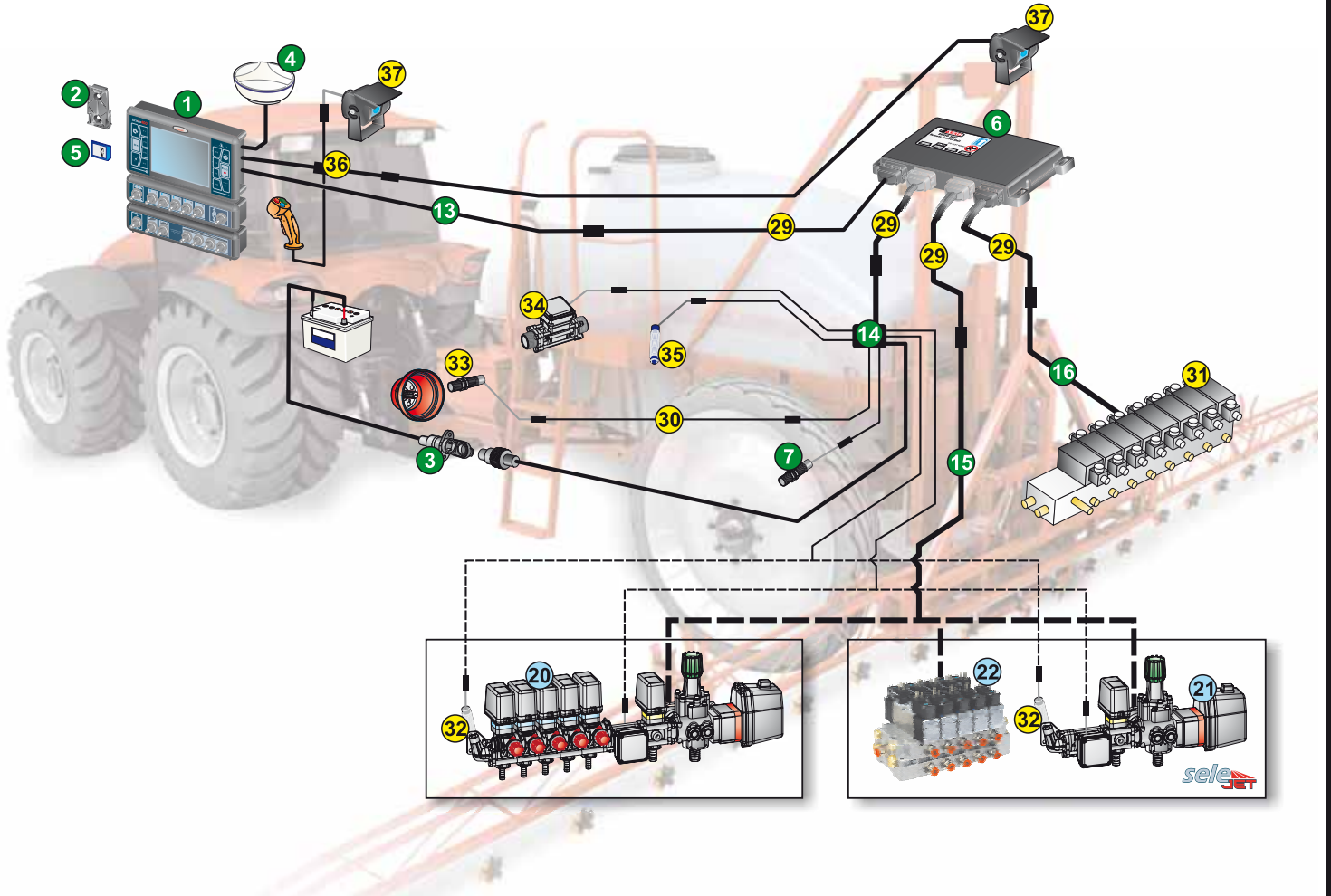

The package includes:

1	Computer
2	Bayonet bracket
3	Panel outlet for power cable
4	Hi-sensitivity GPS receiver complete of magnetic support
5	SD memory card
6	Remote control unit
7	Inductive speed sensor with 5 m cable
13	Computer cable - 10 m
14	Sensor cable - 3 m
15	Water valve cable - 3 m
16	Oil hydraulic valve cable - 3 m
	USB SD memory card reader
	User's and quick guide

To be order separately:

20	Control unit
21	Main SELEJET control unit
22	Air-operated section unit for SELEJET

Accessories:

		CODE
29	'Black' extension cable - 3 m	46732000.110
29	'Grey' extension cable - 3 m	46732000.120
30	Sensor extension - 3 m	466553.220
30	Sensor extension - 5 m	466553.230
31	Hydraulic control unit	
32	Pressure transducer	466112.200 466112.500
33	RPM sensor	467100.100 467100.086
34	Filling flow-meter	
35	Pump Protector	4664000.100
36	Cable for outer main control - 3 m	46730000.090
36	Cable for 1 video camera - 10 m	46740000.090
36	Cable for outer main control - 3 m + cable for 2 video cameras - 10 m	46740000.091
37	Video camera	46700100
37	Separation kit	46740000.500



Video camera for BRAVO 400

CODE
467 00100

Main features

- Infrared night vision
- Adjustable bracket
- Selector for direct or symmetrical vision

Technical features

- CCD 1/3" colour sensor - 512x582 pixels
- Vision angle: 120°
- Cable - 10 m

BRAVO 400 adapter cables for video cameras

CODE	Number of connectable video cameras
467 40000.090	1
467 40000.091	2

BRAVO 400 separation kit

CODE
467 40000.500



INTRODUCTION



MONITOR FOR SEEDER



CODE
467 070

new

Intensive farming needs an ever increasing precision level to optimise operator's job and maximise field production. If applied to seeding, this concept is particularly true as final results depend on correct seed position, successful sowing and fertilisation process. In case of technical problems of the seeder such as clogged lines or part jamming, field production will be impaired thus leading to money loss. **ALFA 310** is designed to control and maximise seeding precision and all linked technical aspects. It is equipped

with advanced electronic systems and innovative software. Furthermore it can be connected with several sowing lines controlled by newly conceived optical sensors.

Operating features

- Graphic page on efficiency level for seeding sensors and fertiliser
- Numeric and graphic display of seeding value up to 48 seeding lines
- Status display up to 48 + 48 fertilisation lines
- Display up to 2 rotation speeds
- 3-point chart of 4 hopper levels
- Shaft rotation control (up to 10)
- SD memory card for completed job storage, settings storage/loading and software updates.
- Automatic brightness control via integrated sensor.
- Special key to quickly display numeric seeding population, sensor dirt level and working data from histogram population page
- Easy installation and maintenance as sensors are all connected with a single serial cable
- Displayable data: instant population (average considering all lines), population for each line, covered seeding distance (average considering all lines), speed, max. reached speed, rotation speed (2), population for surface unit, date and time, field name, sowed surface, average population, average seeding distance, productivity, seeding time, seeding start date and time,
- Buzzers and indicators for: population out of preset values, clogged output, rotation shafts not working, min./max. rotation speed, drive shafts status, low hopper level
- Single sensors can be disabled in case of fault
- Automatic sensor programming according to preset connection sequence

Technical features

- Integrated Secure Digital (SD) memory card reader
- Self-powered internal clock
- Communication port: Alfa-bus
- Selectable language: Italian, English, Spanish, Portuguese, Russian
- Selectable units of measurement: International (ha, km/h) or US (Ac, mph)
- 5.7" backlit graphic display
- Power supply: 12Vdc.



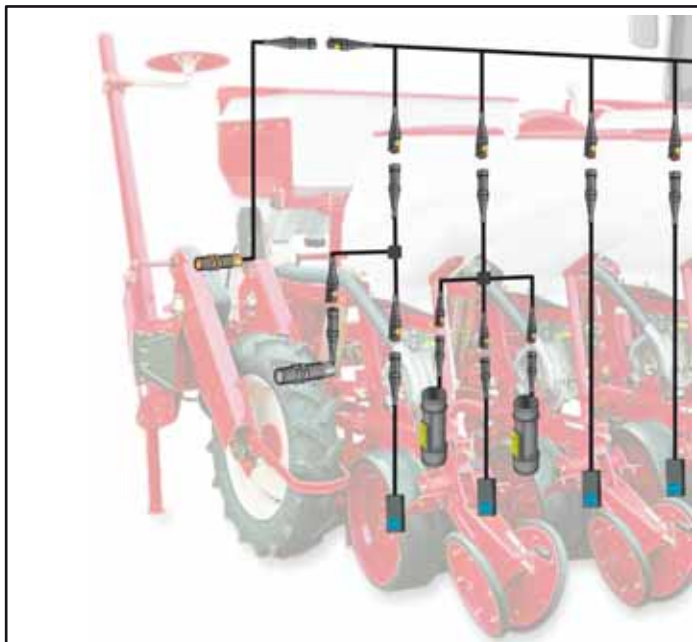

Alfa-bus

Control devices for big seeders are often hard to be installed due to the complexity of the wiring harness involved. ARAG has developed a modular communication system called "Alfa-bus" which allows the installation of additional sensors at any machine position without replacing the existing harness.



SD memory card allows several operations for easier ALFA 310 monitor and data use. ALFA 310 can export completed job data steadily saved while working. Its installation onto the farming machine and remote technical assistance are very easy as monitor settings can be copied onto identical machines or sent to Technical Assistance via e-mail to correct configuration errors. Software updates can be downloaded directly from ARAG website. A sealing cover protects the memory card from dust and water splashes.

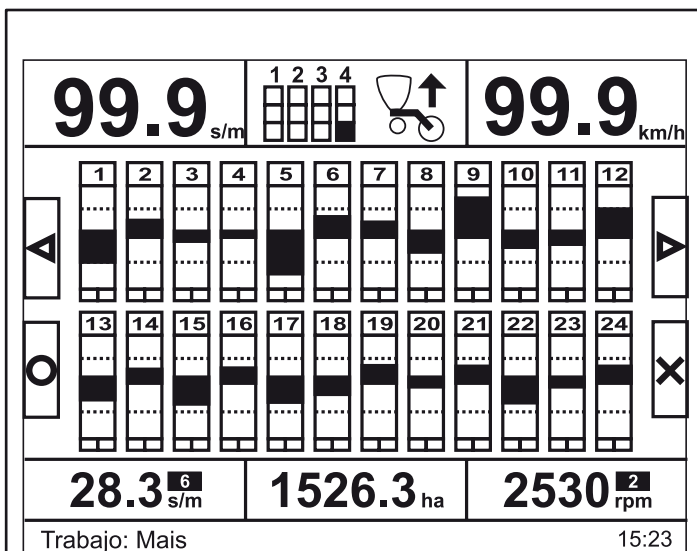

The main page graphically displays the deviation of the seeding value for each single line with respect to the preset value. It also shows all main values, two of which are selectable by the user.

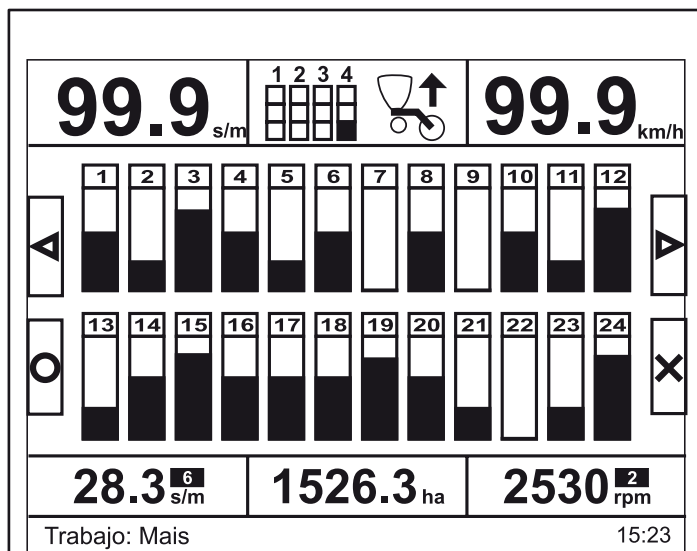

Alfa 310 allows the user to check for sensor efficiency level at any time, which can be lower because the sensor is covered by dust, mud or other materials.



INSTALLATION

INSTALLATION DIAGRAM AND PACKAGE CONTENT

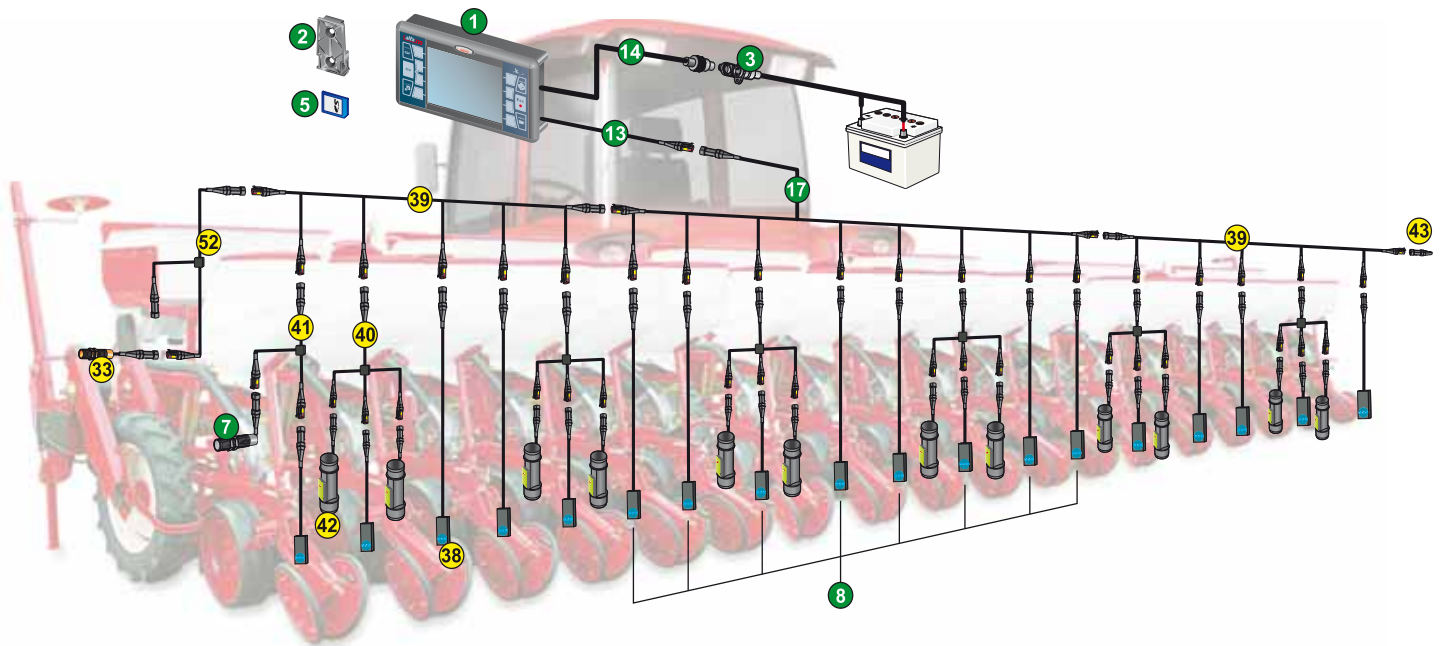

The package includes:

1	Monitor
2	Bayonet bracket
3	Panel outlet for power cable
5	SD memory card
7	Inductive speed sensor
8	No. 8 seeding sensors
13	Intermediate cable - 6 m
14	Power cable - 3 m
17	Cable for 8 sensors
	User's and quick guide

Accessories:

CODE

33	Seeding sensor	467100.086
38	Cable for 5 sensors	467070.201
39	Cable for 3 sensors	467070.110
40	Cable for 1 sensor	467070.120
41	Fertiliser sensor	467070.130
42	RPM sensor	467070.200
43	Connector cover	ECS0040
52	Alfa-bus interface for inductive sensors	467070.203





CODE
467 070.200

Fertiliser sensor kit

Soil can be fertilised twice especially if using big machines. Alfa-bus system allows the easy installation of fertiliser sensors using suitable adapters onto fertiliser supply lines.



CODE
467 070.201

Alfa-bus fertiliser and seeding sensor

- It gives population value, clogged output alarm and sensor efficiency level to the monitor
- Suitable for most drop pipes
- Operation LED
- Clamp seats
- alfa-bus communication system
- Cable - 2 m
- Power supply: 12Vdc.



CODE
467 070.202

Fertiliser sensor adapter

It allows the installation of a sensor onto the fertiliser drop line.

- Inner pipe cross section 42 mm
- Polypropylene
- Easy to inspect



CODE
467 070.203

Alfa-bus interface for inductive sensors

This device allows for connection to the monitor of the ARAG speed, revolution speed, shaft status and seeding status inductive sensors. Connectors layout allows for their connection at end of line or in-line, at any point, with no need of other wiring harness.

- Outputs to monitor the number of pulses read per time unit or sensor status (on/off)
- Alfa-bus communication system
- Cable length: 15 cm
- Power supply: 12Vdc.

INTRODUCTION



SKIPPER and **SKIPPER LT** are two GPS navigators especially designed for farming purposes and for demanding users. Thanks to their large, robust and protected 4" screen, special design and innovative software, they are the right tool for most farming jobs.

Skipper is especially suitable for sprayers connected to Bravo 300S for automatic boom section control and/or variable rate spraying.

Skipper LT is very user-friendly, transportable and with a good price/quality ratio.

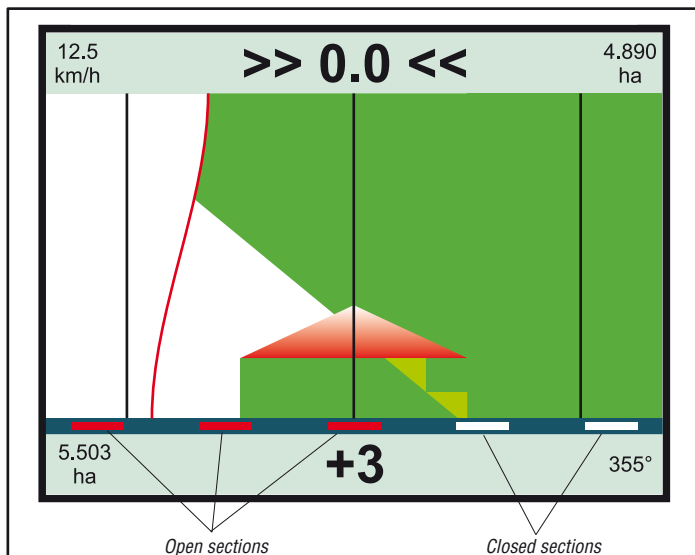

Automatic closing

If connected to Bravo 300S RCU, Skipper can control the automatic closing of up to 13 boom sections. By minimising the extension of areas treated twice, pesticide costs are reduced whereas spraying accuracy is increased. Depending on required results and spraying type, max. allowed overlapping percentage can be set, above which boom sections are closed.

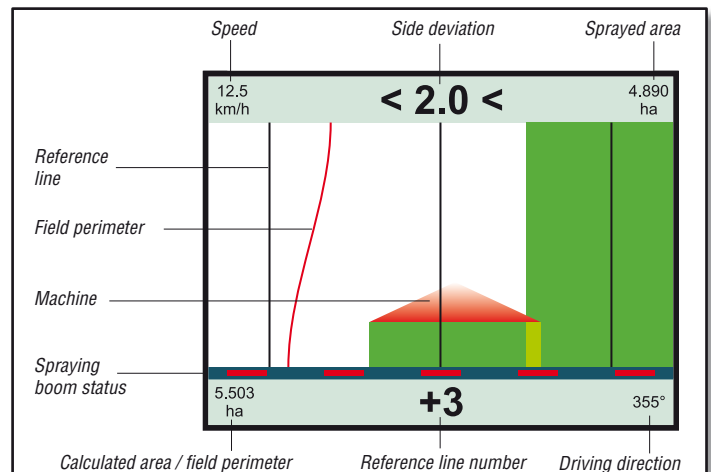

GPS driving

After displaying the driving info page, Skipper is ready to start a new spraying job. Just select the start point (A) and the end point (B) for the first track: all driving information will be displayed. While driving only necessary data are displayed so to leave space to correct track display. Images can be also zoomed in or out. All additional functions displayed as icons can be enabled by pressing the side keys.



Job breaking point

First point of spraying activation

PAUSE

ZOOM -

ZOOM +

DATA

ZOOM ALL

Last point of spraying deactivation

Machine position

General point of interest

Job report

When in the report window, the user can set any zoom level. He/she can also mark a point for later job check or resumption. Skipper will drive the user to the marked point once returned to the driving info page.

120.0 l/ha	130.0 l/ha	140.0 l/ha	160.0 l/ha	200.0 l/ha	300.0 l/ha
------------	------------	------------	------------	------------	------------

22.158 ha

140.0 l/ha

2410 l

Variable spray rate application

The job starts with an accurate data collection on involved field (chemical analysis, satellite picture, analysis of field yield during previous years and so on). Then a direction map is created by installed analysis and simulation software. This map indicates the spray rate to be used in each position for an optimal yield at minimum costs and minimum working time. At this point the direction map can be uploaded onto Skipper via Pen Drive. According to the position detected by the GPS receiver, Bravo 300S will use the spray rate specified for the area being sprayed.



Skipper can both import direction maps or export completed job data by connecting a Pen Drive to its USB port. Skipper installation and remote technical assistance are very easy as its settings can be copied onto identical machines or sent to Technical Assistance via e-mail to correct configuration errors. Software updates can be downloaded directly from ARAG website.



FEATURES



CODE
467 031

- Automatic section closing
- Variable rate spray control
- USB port
- 4" display

Main features

- Main valve automatically closes when onto a previously sprayed area (if Bravo 300S is connected).
- Sections automatically close when spraying onto an adjacent area (if Bravo 300S RCU is connected).
- Variable spray rate control
- Driving mode: "Parallel", "Curved parallel" and "Contour".
- Calculation of field area and perimeter
- Pen Drive can be connected for completed job storage, settings storage/loading and software updates.
- Buzzer for correct steering time to properly centre next track depending on preset steering radius.
- Realignment function for lined crops such as maize, cane and so on.
- Display of number of lines, distance and direction to return to the job breaking points.
- Day/night operating mode
- Alarms for: spraying overlapping, poor GPS accuracy, no DGPS signal
- Displayable data: side deviation, track number, calculated surface, field perimeter, direction, covered area, oversprayed surface, untreated surface
- Displayable GPS data: latitude, longitude, altitude, number of satellites, index of signal degradation (HDOP), DGPS signal availability.
- Completed job overview, zooming in or out and storage of unsprayed areas to allow job completion.
- Automatic correction of position error due to machine inclination via ATD sensor (to be ordered separately).
- Skipper can be informed on spraying status (on/off) by pressing a special key or via outer signal
- Driving page can be zoomed in or out according to operator's needs.
- Storage and display of points of interests.
- 2D or 3D driving indications.

Outer GPS receiver features

- Free WAAS/EGNOS/MSAS differential correction (USA, Europe and Japan only)
- Status illuminated indicators for: valid GPS signal, valid differential correction and power on
- Threaded or magnetic support

Technical features

- USB port
- Input for spraying status outer signal
- 2 RS232 serial ports for GPS and Bravo 300S connection
- Internal clock, self-powered and automatically set via GPS.
- Selectable language: Italian, English, Spanish, French, Portuguese, German, Polish, Russian and Czech.
- Selectable units of measurement: International (ha, km/h) or US (Ac, mph)
- 4" TFT graphic colour display.
- Power supply: 12Vdc.

INSTALLATION DIAGRAM AND PACKAGE CONTENT

The package includes:

1	SKIPPER
2	Bayonet bracket
4	Hi-sensitivity GPS receiver complete of magnetic support
14	Power cable - 6 m and connection cable for BRAVO 300S - 3 m
18	Cable for outer receiver - 4 m
	User's and quick guide

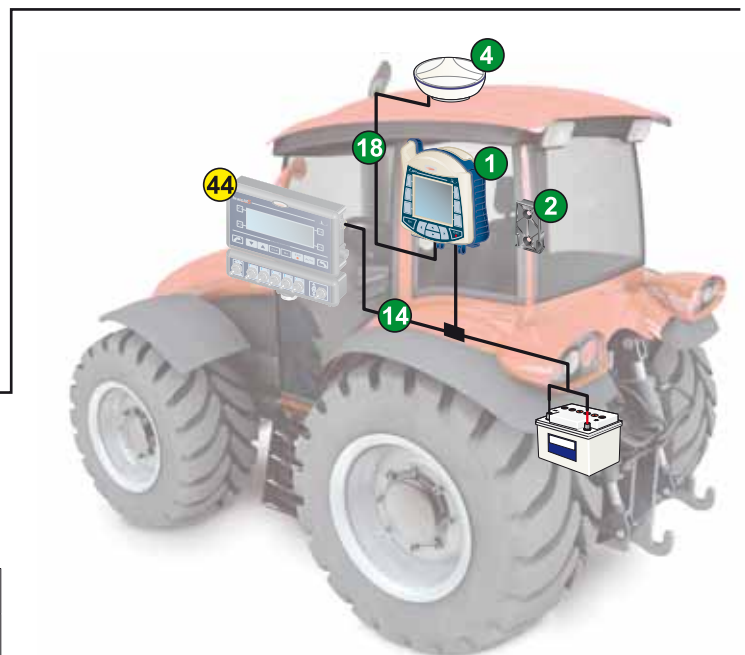

Accessories to be ordered separately:

44	BRAVO 300S
	Suction cup support (page 50)



CODE
467 020

- Good quality/price ratio
- Integrated GPS receiver
- USB port
- 4" display



Main features

- Driving mode: "Parallel", "Curved parallel" and "Contour".
- Calculation of field area and perimeter
- Pen Drive can be connected for completed job storage, settings storage/loading and software updates.
- Buzzer for correct steering time to properly centre next track depending on preset steering radius.
- Realignment function for lined crops such as maize, cane and so on.
- Display of number of lines, distance and direction to return to the job breaking points.
- Day/night operating mode
- Alarms for: spraying overlapping, poor GPS accuracy, no DGPS signal
- Displayable data: side deviation, track number, calculated surface, field perimeter, direction, area covered, oversprayed surface, untreated surface
- Displayable GPS data: latitude, longitude, altitude, number of satellites, index of signal degradation (HDOP), DGPS signal availability.
- Skipper can be informed on spraying status (on/off) by pressing a special key or via outer signal
- Completed job overview, zooming in or out and storage of unsprayed areas to allow job completion.
- Driving page can be zoomed in or out according to operator's needs.
- Storage and display of points of interests.
- 2D or 3D driving indications.

Technical features

- Integrated GPS receiver with free WAAS/EGNOS/MSAS differential correction (USA, Europe and Japan only)
- Magnetic aerial featuring low noise design (0.5 dB) LNA
- USB port
- Input for spraying status outer signal
- RS232 serial port for GPS (NMEA) data output
- Pulse progress speed signal output
- Internal clock, self-powered and automatically set via GPS.
- Selectable language: Italian, English, Spanish, French, Portuguese, German, Polish, Russian and Czech.
- Selectable units of measurement: International (ha, km/h) or US (Ac, mph)
- 4" TFT graphic colour display.
- Power supply: 12Vdc.

INSTALLATION DIAGRAM AND PACKAGE CONTENT

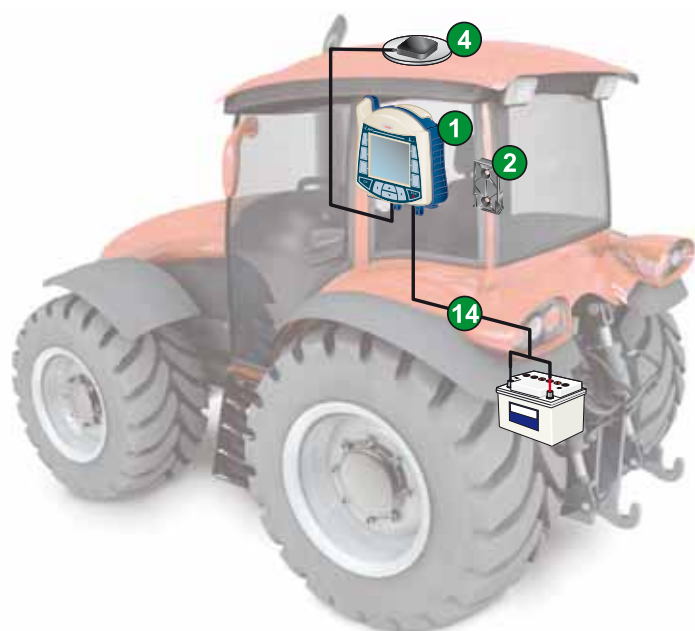

The package includes:

1	SKIPPER
2	Bayonet bracket
4	Outer GPS aerial with cable - 4 m
14	Power cable - 6 m + outer application control
	User's and quick guide

Accessories to be ordered separately:

	Suction cup support (page 50)
--	-------------------------------

FEATURES

SIRIO LT is the satellite system which combines the best technology with the lowest price. It supersedes traditional foam markers while being extremely user-friendly even for GPS novices.



Backlit control keyboard



CODE
520 110

Angle indicator displays the necessary correction -expressed in degrees- to follow the exact path.

SIRIO displays a number of indications and alarms in several languages.

Side deviation bar shows how the tractor is moving away from the ideal track and how it can be perfectly realigned.



Main features

- Driving mode: "Parallel" and "Contour"
- Calculation of field area and perimeter
- Display of distance and direction to return to the job breaking point.
- Brightness adjustment
- Displayable data: side deviation, track number, calculated surface, direction, covered area
- Alarms for: spraying overlapping, poor GPS accuracy, no DGPS signal
- Realignment function for lined crops such as maize, cane and so on.
- Buzzer for correct steering time to properly centre next track depending on preset steering radius.
- Displayable GPS data: number of satellites, index of signal degradation (HDOP), DGPS signal availability
- Separate backlit control keyboard
- Sirio LT can be informed on spraying status (on/off) by pressing a special key or via outer signal

Technical features

- Integrated GPS receiver with free WAAS/EGNOS/MSAS differential correction (USA, Europe and Japan only)
- Magnetic aerial featuring reduced interference sensitivity (0.5 dB) LNA
- Pulse progress speed signal output
- Input for spraying status outer signal
- RS232 serial port for GPS (NMEA) data output
- Selectable language: Italian, English, Spanish, French, Portuguese, German, Polish, Russian, Czech, Hungarian, Dutch and Danish.
- Selectable units of measurement: International (ha, km/h) or US (Ac, mph)
- Alphanumeric 10-digit display
- Side deviation 25-LED bar
- Angle deviation 15-LED bar
- Power supply: 12Vdc.

INSTALLATION DIAGRAM AND PACKAGE CONTENT

The package includes:

1	SIRIO LT
2	Bayonet bracket
4	GPS aerial with cable - 4 m
9	Adjustable bracket for SIRIO LT plus suction cup
10	Keyboard with cable - 3 m
14	Power cable - 6 m + outer application control
	User's and quick guide

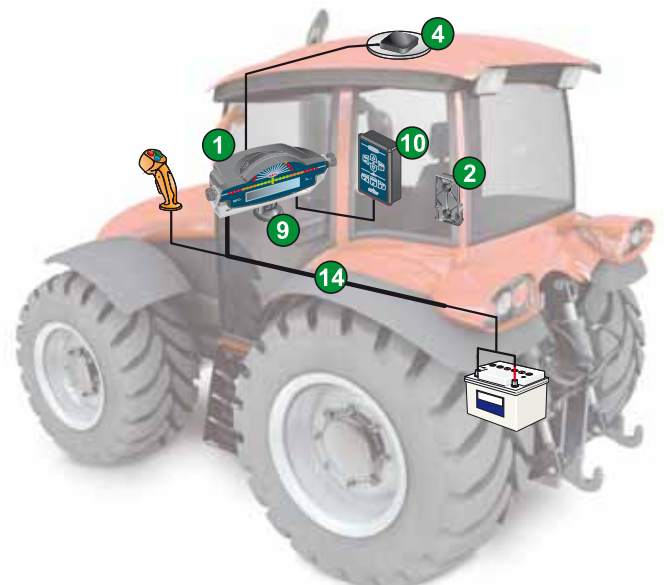

INTRODUCTION



Bravo300S is a medium-high quality product designed to meet different requirements. Available for each spraying job both with direct and CANBUS connection via remote control unit, it is perfect also for very demanding users. SELEJET nozzle holder control commanding up to 13 water sections and 9 oil sections, connectable with GPS navigation systems and featuring a graphic display in several languages.

Suitable also for contract workers as it collects working data which can be later downloaded and displayed on PC.

As Bravo300S sets new spraying standards it has become very popular worldwide in a very short time.

Large backlit graphic display always showing: preset and actual spray rate, speed, flow rate, pressure, tank level (numeric and graphic display), time, rpm (or covered area), low level and fault alarms

Display of calculated pressure even with no pressure sensors fitted

Graphic indicator for tank level



Socket for main valve outer control via switch/joystick/pedal and GPS receiver

ON/OFF key

LED indicators for enabled foam marker side and valve status

Large watertight switches for improved ergonomic design

13 valves controlled by only 2 switches which sequentially open and close all sections.



Sequential control allows the user to command up to 13 bar sections using two switches only, one for the right side and one for the left side. A special software controlling boom sections allows the operator to work according to the preset mode and control more sections or half booms at the same time by simply activating a control.



MAIN FEATURES



Air-operated control unit on page 50

Nowadays farmers require higher spraying rates. Variable spray rate requires immediate system action which cannot be granted with traditional spraying systems. This is why ARAG decided to develop a system which can automatically select either nozzles or a special combination of them to be fully controlled by the computer for optimal spraying results even on difficult areas. BRAVO 300S can control an air-operated control unit connected with new SELEJET nozzles (please refer to ARAG C106 main catalogue) for quick and precise spraying.



The Remote Control Unit (RCU) communicates with the computer through a single cable having CANBUS protocol. RCU ensures an easier installation especially in towed machines and the control of hydraulic units moving the booms. The monitor can be detached from the whole system by disconnecting only a single cable. Its special slide connectors and its watertight body allow a safe installation even in points splashed with water or subject to weather conditions.



SD memory card serves as connection unit between BRAVO 300S and other devices. It allows several operations for easier computer and data use. BRAVO 300S can both import direction maps from the card and export completed job data, regularly saved while spraying. Its installation onto the farming machine and remote technical assistance are very easy as computer settings can be copied onto identical machines or sent to Technical Assistance via e-mail to correct configuration errors. Software updates can be downloaded directly from ARAG website. A sealing cover protects the memory card from dust and water splashes.

Job selection			
>01)	60 l/ha	* IS001	Orange
02)	90 l/ha	IS0015	Green
03)	120 l/ha	IS002	Yellow
04)	Variable	IS0025	Lilac
05)	200 l/ha	IS003	Blue
06)	250 l/ha	IS004	Red

Bravo 300S allows the operator to preset up to 19 working programs including spray rate and nozzle selection. This feature helps avoiding input errors by the operator and speeds up the setting stage as preset programs can be selected by pressing one key only.

In the multi-row version the working program is given by spray rate/distance between two rows.

In the orchard sprayer version the working program is given by spray rate/distance between two rows/boom configuration (i.e. the configuration of used nozzles) since this ensures correct spray rate calculation in multifractioned machines.

CROP SPRAYER - MULTI-ROW SPRAYER - SEQUENTIAL SPRAYER



- Control of up to 13 sections
- Hydraulic boom controls
- Automatic section closing control
- Remote control unit (RCU)
- SD memory card slot

Main features

- Automatic boom section closing control with Skipper help to avoid treating the same area twice.
- Variable spray rate control with Skipper help.
- SD memory card for completed job storage, settings storage/loading and software updates.
- Nozzle wear check via simultaneous reading of flow rate and pressure values
- Graphic indicator for tank level
- Displayable data: instant spray rate, supplied spray rate, speed, pressure, flow rate, distributed amount, tank level, rotation speed, covered area, spraying time, productivity, date and time, covered distance
- Nozzle wear check via simultaneous reading of flow rate and pressure values
- Automatic spraying stop if pressure value drops under preset min. value so that nozzles work within their operating range.
- Automatic closing of main valve under min. preset speed.
- Alarms for: preset spray rate not reached, tank low level, min./max. nozzle working pressure, min./max. rotation speed, flow-meter out of operating range, excessively worn-out nozzles
- Automatic switch to pressure sensor if the flow-meter works outside preset limits.
- Temporary increase and reduction of distributed fluid.
- Storage of 19 combinations of spray rate/nozzle to be activated before starting spraying.
- Automatic adjustment via flow rate and/or pressure detection (by flow-meter or pressure sensor)

Technical features

- Integrated Secure Digital (SD) memory card reader
- Input for main valve outer control
- RCU
- RS232 serial port for GPS or Skipper connection
- Self-powered internal clock
- Inputs for signals of: flow rate, speed, pressure, filling flow rate, revolution counter, Pump Protector.
- Outputs to control up to 7 boom sections (13 in the sequential version), control valve, main valve and foam marker
- Outputs to control up to 9 hydraulic functions and drain valve
- Selectable language: Italian, English, Spanish, French, Portuguese, German, Polish, Russian and Czech.
- Selectable units of measurement: International (ha, km/h) or US (Ac, mph)
- Graphic backlit display - 240x73 pixels
- Power supply: 12Vdc.



Crop Sprayer Version

CODE	Ways	Hydraulic functions
467 32501	5	0
467 32701	7	0
467 32511	5	7
467 32711	7	7
467 32721	7	9

Sequential Version

CODE	Ways	Hydraulic functions
467 32D01	8÷13	---
467 32D11	8÷13	7
467 32D21	8÷13	9

The sequential computer works only if connected to 3-wire valves.

When ordering a single valve please add a T at the end of the relevant part number or order a control unit.



Multi-row version

CODE	Ways	Hydraulic functions
467 33511	5	7
467 33711	7	7
467 33721	7	9

CROP SPRAYER - SEQUENTIAL SPRAYER

INSTALLATION DIAGRAM AND PACKAGE CONTENT

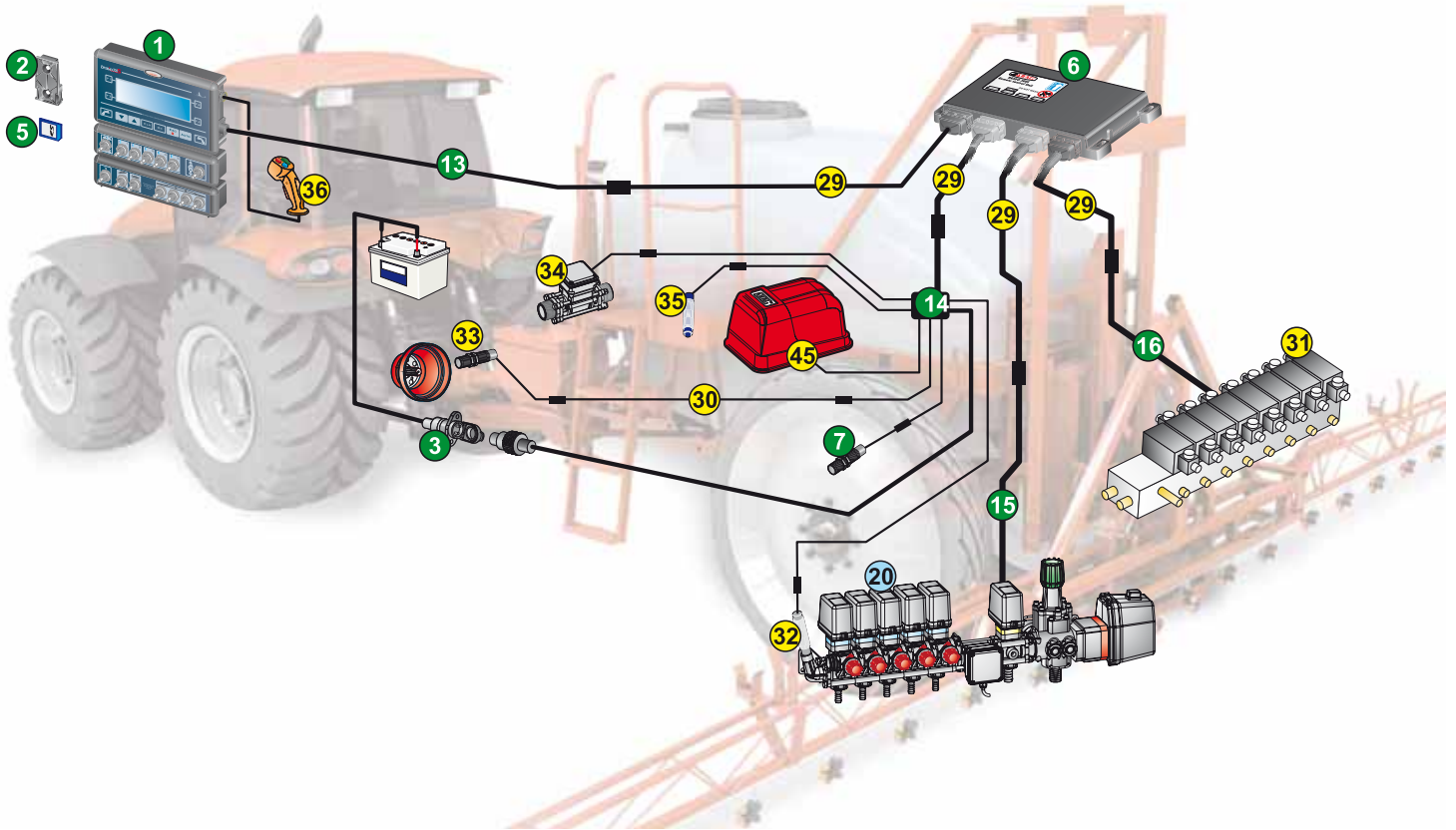

The package includes:

1	Computer
2	Bayonet bracket
3	Panel outlet for power cable
5	SD memory card
6	Remote control unit
7	Inductive speed sensor with 5 m cable
13	Computer cable - 10 m
14	Sensor cable - 3 m + power cable - 5 m
15	Water valve cable - 3 m
16	Oil hydraulic valve cable - 3 m
	User's and quick guide

To be order separately:

20	Control unit
----	--------------

Accessories:

CODE

29	"Black" extension cable - 3 m	46732000.110
29	"Grey" extension cable - 3 m	46732000.120
30	Sensor extension cable - 3 m	466553.220
30	Sensor extension cable - 5 m	466553.230
31	Hydraulic control unit	
32	Pressure transducer	466112.200 466112.500
33	RPM sensor	467100.100 467100.086
34	Filling flow-meter	
35	Pump Protector	4664000.100
36	Cable for main outer control	46730000.090
45	Foam marker	520 005C 520 0052C



INSTALLATION DIAGRAM AND PACKAGE CONTENT

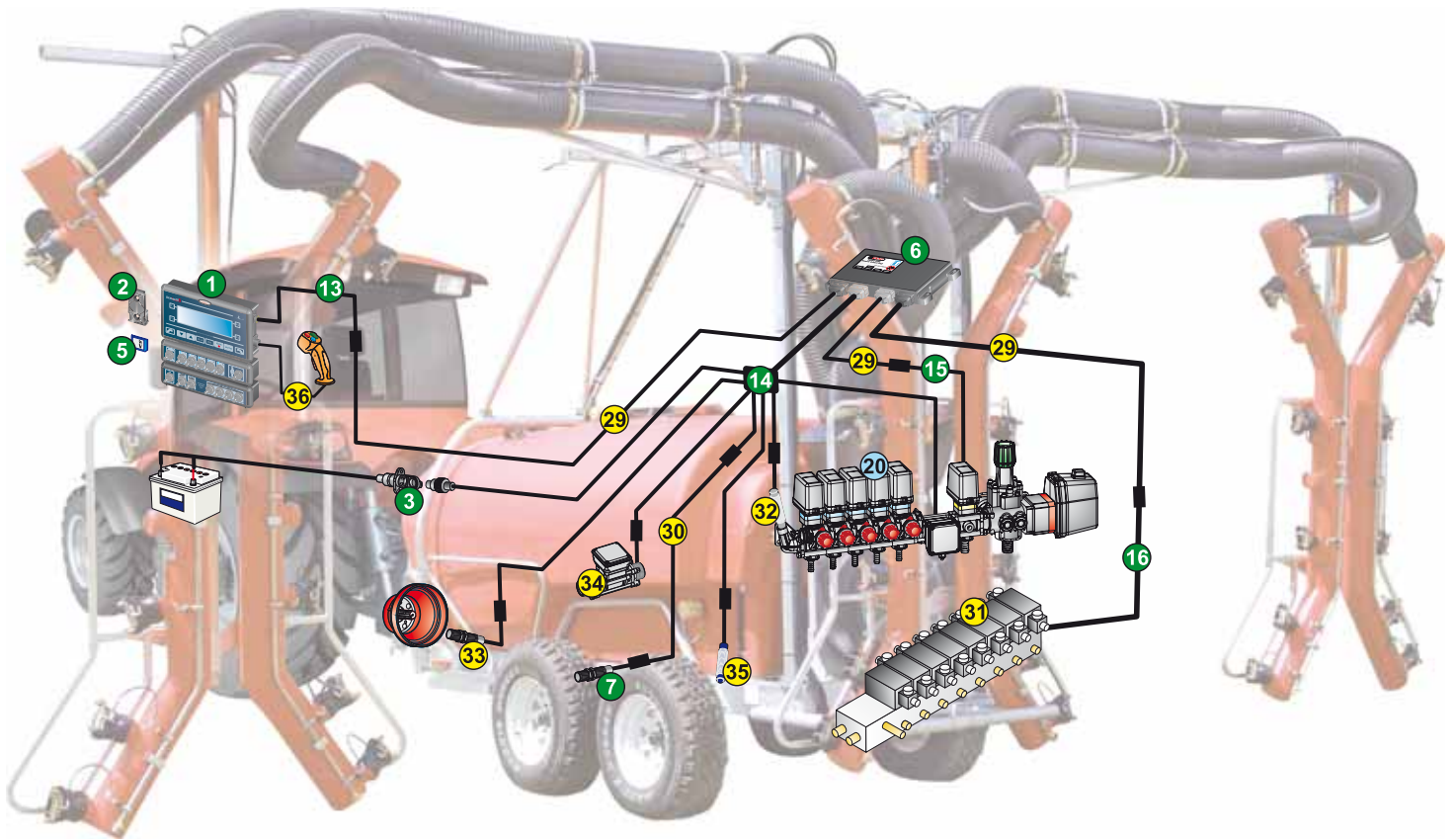

The package includes:

1	Computer
2	Bayonet bracket
3	Panel outlet for power cable
5	SD memory card
6	Remote control unit
7	Inductive speed sensor with 5 m cable
13	Computer cable - 10 m
14	Sensor cable - 3 m + power cable - 5 m
15	Water valve cable - 3 m
16	Oil hydraulic valve cable - 3 m
	User's and quick guide

To be order separately:

20	Control unit
----	--------------

Accessories:

		CODE
29	"Black" extension cable - 3 m	46732000.110
	"Grey" extension cable - 3 m	46732000.120
	Sensor extension cable - 3 m	466553.220
30	Sensor extension cable - 5 m	466553.230
31	Hydraulic control unit	
32	Pressure transducer	466112.200 466112.500
33	RPM sensor	467100.100 467100.086
34	Filling flow-meter	
35	Pump Protector	4664000.100
36	Cable for main outer control	46730000.090

DIRECT-CONNECTION CROP SPRAYER - MULTI-ROW SPRAYER

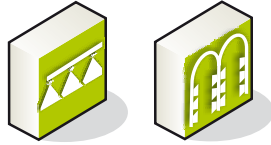

- Automatic nozzle selection (only SELEJET version)
- Control of up to 7 boom sections
- SD memory card slot

- Special software for multi-row machines
- SD memory card slot
- Good performance/price ratio

Crop Sprayer Version	
CODE	Ways
467 30401	4
467 30501	5
467 30701	7

version for SELEJET	
CODE	Ways
467 36501	5
467 36701	7



Multi-row version	
CODE	Ways
467 31401	4
467 31501	5
467 31701	7

Main features

- Automatic nozzle selection while spraying (only Selejet)
- Automatic main valve closing with the help of Skipper when driving along a sprayed track.
- Variable spray rate control with Skipper help.
- SD memory card for completed job storage, settings storage/loading and software updates.
- Nozzle wear check via contemporaneous reading of flow rate and pressure values
- Graphic indicator for tank level
- Displayable data: instant spray rate, supplied spray rate, speed, pressure, flow rate, distributed amount, tank level, rotation speed, covered area, spraying time, productivity, date and time, covered distance
- Nozzle wear check via contemporaneous reading of flow rate and pressure values
- Automatic spraying stop if speed value drops under preset min. value so that nozzles work within their operating range.
- Automatic closing of main valve under min. preset speed.
- Alarms for: preset spray rate not reached, tank low level, min./max. nozzle working pressure, min./max. rotation speed, flow-meter out of operating range, excessively worn-out nozzles
- Automatic switch to pressure sensor if the flow-meter works outside preset limits.
- Temporary increase and reduction of distributed fluid.
- Storage of 19 combinations of spray rate/nozzle to be activated before starting spraying.
- Automatic adjustment via flow rate and/or pressure detection (by flow-meter or pressure sensor)

Technical features

- Integrated Secure Digital (SD) memory card reader
- Input for main valve outer control
- RS232 serial port for GPS or Skipper connection
- Self-powered internal clock
- Inputs for signals of: flow rate, speed, pressure, filling flow rate, revolution counter, Pump Protector.
- Outputs to control up to 7 boom sections (14 in the sequential version), control valve, main valve and foam marker
- Selectable language: Italian, English, Spanish, French, Portuguese, German, Polish, Russian and Czech.
- Selectable units of measurement: International (ha, km/h) or US (Ac, mph)
- Graphic backlit display - 240x73 pixels
- Power supply: 12Vdc.



INSTALLATION DIAGRAM AND PACKAGE CONTENT

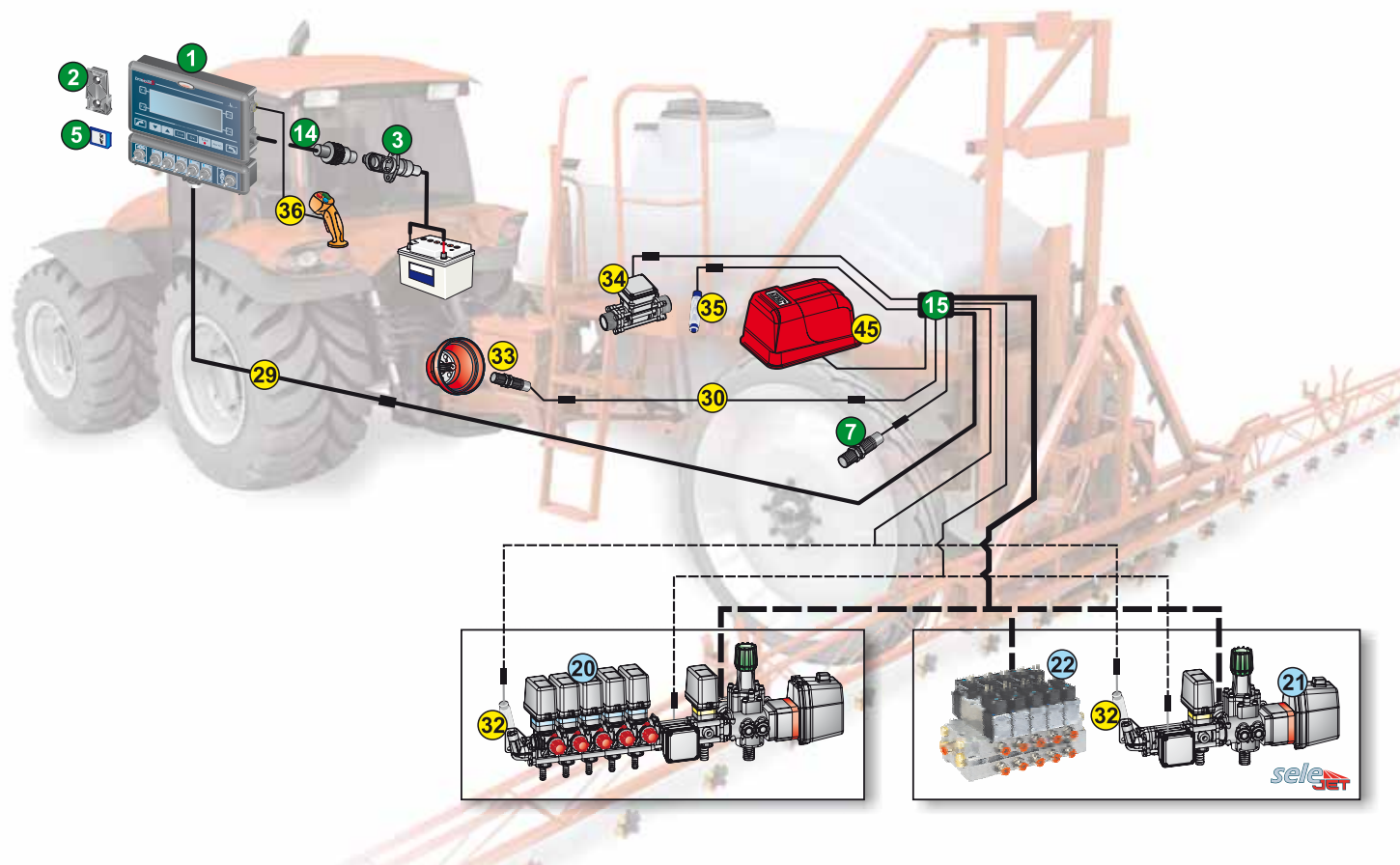

The package includes:

1	Computer
2	Bayonet bracket
3	Panel outlet for power cable
5	SD memory card
7	Inductive speed sensor with 5 m cable
14	Power cable - 3 m
15	Valve and sensor cable - 6 m
	User's and quick guide

To be order separately:

20	Control unit
21	Main control unit for SELEJET
22	Air-operated section unit for SELEJET (page 50)

Accessories:

		CODE
29	Extension cable 4/5 sect. - 3 m	467305.110
	Extension cable 7 sect. - 3 m	467307.110
30	Sensor extension cable - 3 m	466553.220
	Sensor extension cable - 5 m	466553.230
32	Pressure transducer	466112.200 466112.500
	33	RPM sensor
34	Filling flow-meter	
35	Pump Protector	4664000.100
36	Cable for main outer control	46730000.090
45	Foam marker	520 005C 520 0052C
	Wiring harness connector cover 4 and 5 sections	ECS0023
	Wiring harness connector cover 7 sections	ECS0024



DIRECT-CONNECTION MULTI-ROW SPRAYER

INSTALLATION DIAGRAM AND PACKAGE CONTENT

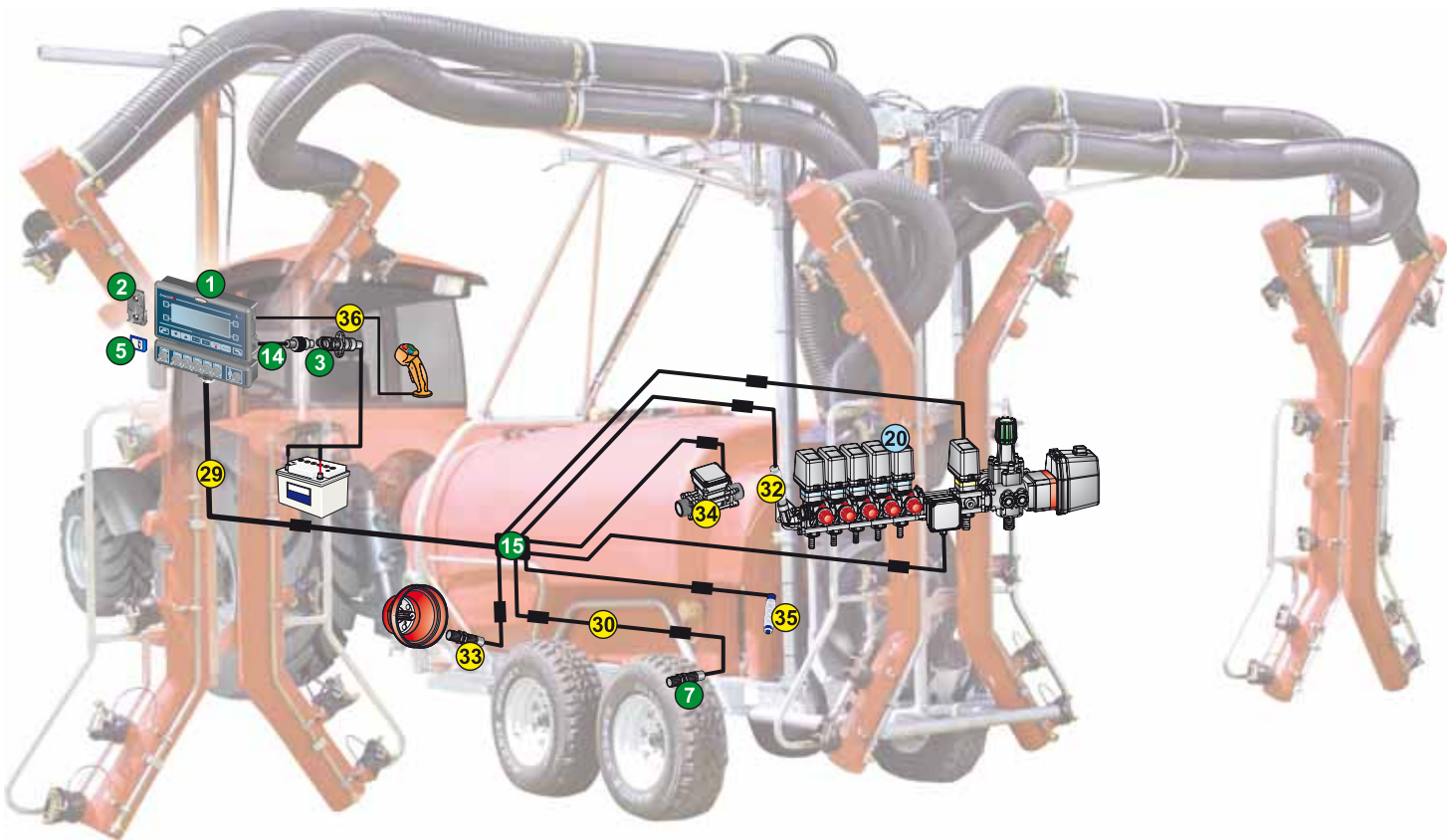

The package includes:

1	Computer
2	Bayonet bracket
3	Panel outlet for power cable
5	SD memory card
7	Inductive speed sensor with 5 m cable
14	Power cable - 3 m
15	Valve and sensor cable - 6 m
	User's and quick guide

To be order separately:

20	Control unit with flow-meter
----	------------------------------

Accessories:

		CODE
	Extension cable 4/5 sect. - 3 m	467305.110
29	Extension cable 7 sect. - 3 m	467307.110
	Sensor extension cable - 3 m	466553.220
30	Sensor extension cable - 5 m	466553.230
	Pressure transducer	466112.200 466112.500
	RPM sensor	467100.100 467100.086
34	Filling flow-meter	
35	Pump Protector	4664000.100
36	Cable for main outer control	46730000.090
	Wiring harness connector cover 4 and 5 sections	ECS0023
	Wiring harness connector cover 7 sections	ECS0024

DIRECT-CONNECTION ORCHARD SPRAYER



- Special software for multifractioned fan orchard sprayer
- SD memory card slot
- Good performance/price ratio



Orchard sprayer version

CODE	Ways
467 34401	4

Main features

- Storage of 19 spray rate/distance between two rows/boom configuration combinations to be recalled before starting spraying
- Storage of up to 10 configurations
- Variable spray rate control with Skipper help.
- SD memory card for completed job storage, settings storage/loading and software updates.
- Nozzle wear check via contemporaneous reading of flow rate and pressure values
- Graphic indicator for tank level
- Displayable data: instant spray rate, supplied spray rate, speed, pressure, flow rate, distributed amount, tank level, rotation speed, sprayed surface, spraying time, productivity, date and time, covered distance
- Nozzle wear check via contemporaneous reading of flow rate and pressure values
- Automatic spraying stop if pressure value drops under preset min. value so that nozzles work within their operating range.
- Automatic closing of main valve under min. preset speed.
- Alarms for: preset spray rate not reached, tank low level, min./max. nozzle working pressure, min./max. rotation speed, flow-meter out of operating range, excessively worn-out nozzles
- Automatic switch to pressure sensor if the flow-meter works outside preset limits.
- Temporary increase and reduction of distributed fluid.
- Automatic adjustment via flow rate and/or pressure detection (by flow-meter or pressure sensor)

Technical features

- Integrated Secure Digital (SD) memory card reader
- Input for main valve outer control
- RS232 serial port for GPS or Skipper connection
- Self-powered internal clock
- Inputs for signals of: flow rate, speed, pressure, filling flow rate, revolution counter, Pump Protector.
- Outputs to control up to 7 boom sections, control valve and main valve
- Selectable language: Italian, English, Spanish, French, Portuguese, German, Polish, Russian and Czech.
- Selectable units of measurement: International (ha, km/h) or US (Ac, mph)
- Graphic backlit display - 240x73 pixels
- Power supply: 12Vdc.



DIRECT-CONNECTION ORCHARD SPRAYER

INSTALLATION DIAGRAM AND PACKAGE CONTENT

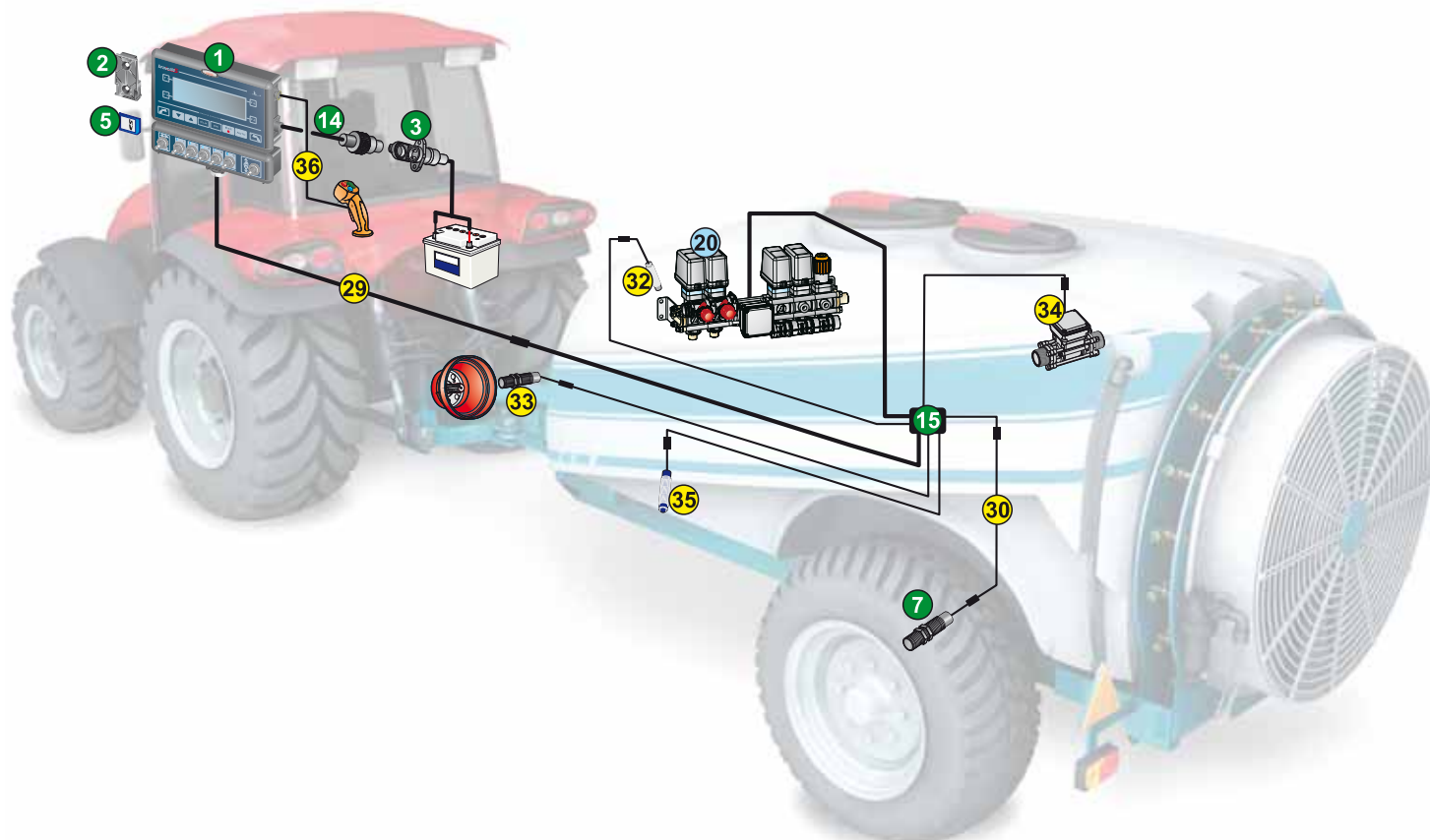

The package includes:

1	Computer
2	Bayonet bracket
3	Panel outlet for power cable
5	SD memory card
7	Inductive speed sensor with 5 m cable
14	Power cable - 3 m
15	Valve and sensor cable - 6 m
	User's and quick guide

To be order separately:

20	Control unit with flow-meter
----	------------------------------

Accessories:

		CODE
29	Extension cable 4/5 sect. - 3 m	467305.110
	Extension cable 7 sect. - 3 m	467307.110
30	Sensor extension cable - 3 m	466553.220
	Sensor extension cable - 5 m	466553.230
32	Pressure transducer	466112.200 466112.500
33	RPM sensor	467100.100 467100.086
34	Filling flow-meter	
35	Pump Protector	4664000.100
36	Cable for main outer control	46730000.090
	Wiring harness connector cover 4 and 5 sections	ECS0023
	Wiring harness connector cover 7 sections	ECS0024

CROP SPRAYER - MULTI-ROW SPRAYER



Bravo 180 is the smallest computer belonging to our Precision Farming range but still offering high performances. A compact and cost-effective tool but extraordinarily efficient and precise to meet all requirements of small-medium farming machine operators.

Main features

- Special key to recall up to 5 preset spray rate values
- Displayable data: spray rate, speed, calculated pressure, flow rate, distributed amount, tank level, covered area, spraying time, covered distance
- Alarms for: preset spray rate not reached, tank low level
- Temporary increase and reduction of distributed fluid.
- Storage of up to 5 job reports

Technical features

- LED indicators for valve status.
- Inputs for flow rate and speed signals
- Outputs to control up to 5 boom sections, control valve, main valve and foam marker
- Selectable language: Italian, English, French, Portuguese, Spanish, Russian, German and Polish.
- Selectable units of measurement: International (ha, km/h), US (Ac, mph) and golf course units (US Gallon /1000sqft).
- Backlit alphanumeric display - 2 lines x 16 digits
- Different types of sensors can be connected
- Connection port for printer or PC
- Power supply: 12Vdc.



Crop Sprayer Version			
CODE	Sections	General	Pressure
467 18001	-	•	•
467 18301	3	•	•
467 18401	4	•	•
467 18501	5	•	•

- Good performance/price ratio
- Easy use and programming
- Message display in 8 languages



Multi-row version	
CODE	Ways
467 18251	2
467 18351	3
467 18451	4
467 18551	5

- Special software for multi-row orchard sprayer
- Special keys for row width and spray rate
- Operating pressure display



CROP SPRAYER

INSTALLATION DIAGRAM AND PACKAGE CONTENT

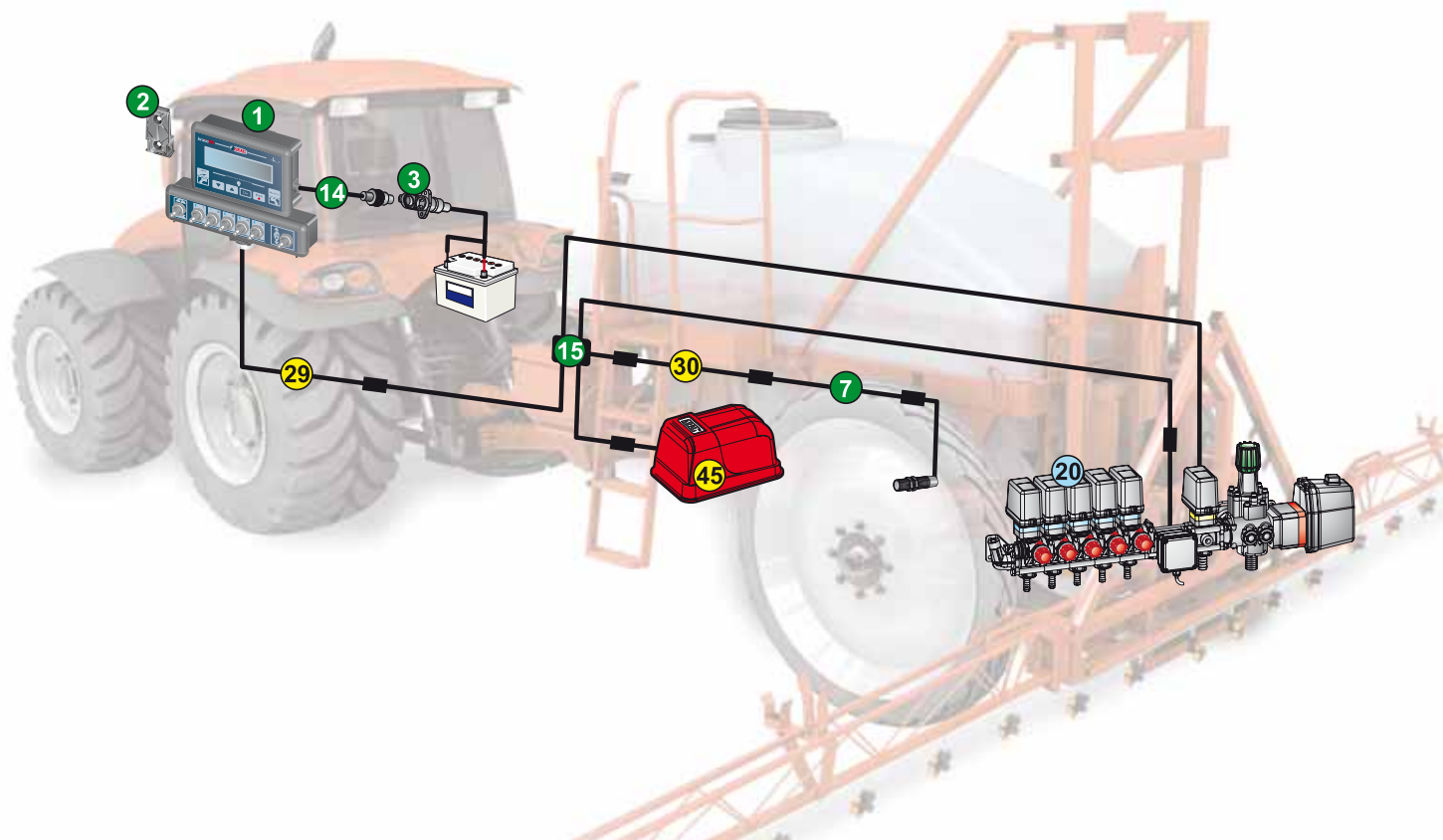

The package includes:

1	Computer
2	Bayonet bracket
3	Panel outlet for power cable
7	Inductive speed sensor with 5 m cable
14	Power cable - 3 m
15	Valve and sensor cable - 6 m
	User's and quick guide

To be order separately:

20	Control unit with flow-meter
----	------------------------------

Accessories:

		CODE
29	Extension cable - 3 m	467305.110
30	Sensor extension cable - 3 m	466553.220
	Sensor extension cable - 5 m	466553.230
45	Foam marker	520 005C 520 0052C
	Wiring harness connector cover	ECS0023



INSTALLATION DIAGRAM AND PACKAGE CONTENT

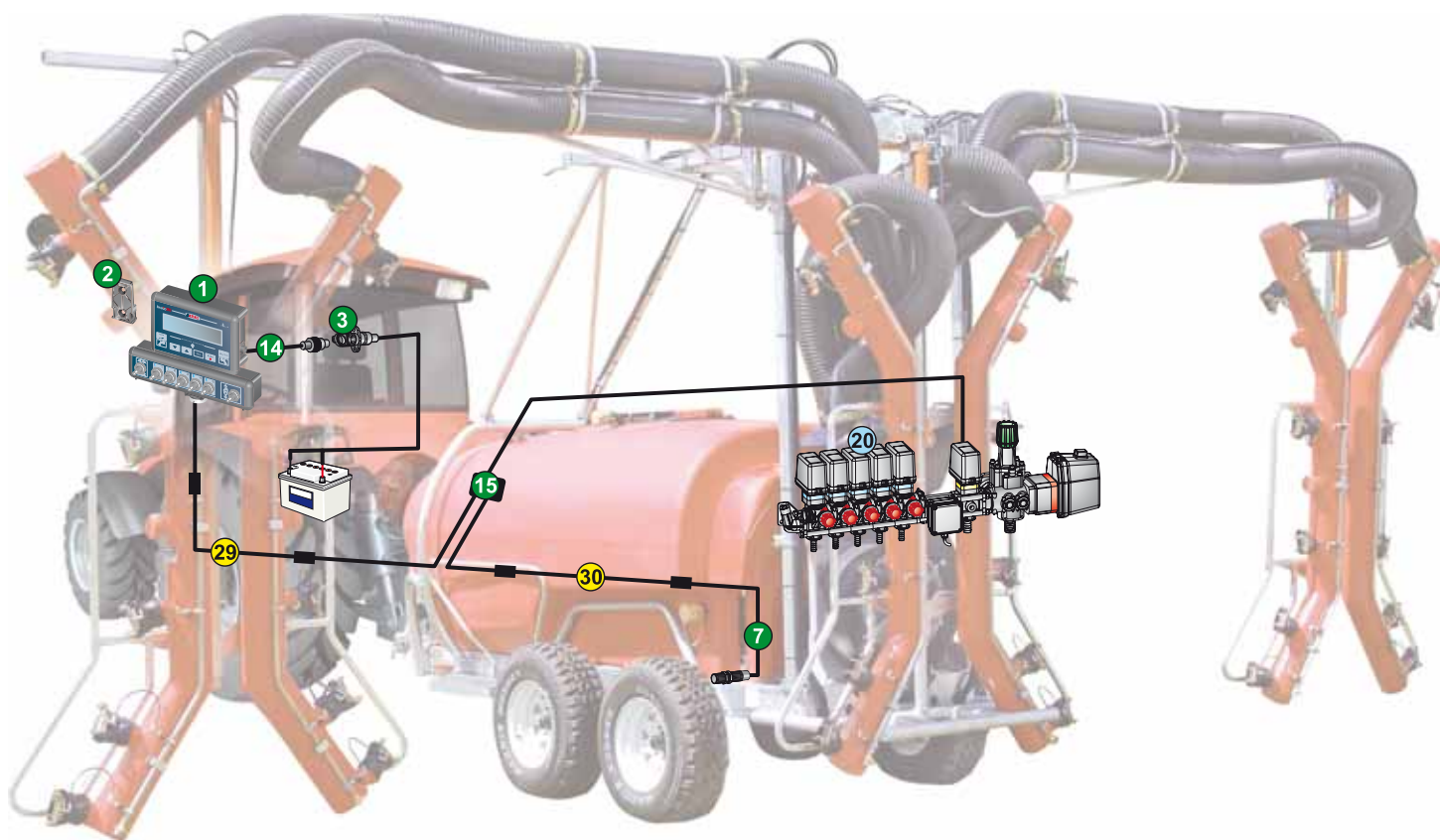

The package includes:

1	Computer
2	Bayonet bracket
3	Panel outlet for power cable
7	Inductive speed sensor with 5 m cable
14	Power cable - 3 m
15	Valve and sensor cable - 4 m
	User's and quick guide

To be order separately:

20	Control unit with flow-meter
----	------------------------------

Accessories:

		CODE
29	Extension cable - 3 m	467305.110
	Sensor extension cable - 3 m	466553.220
30	Sensor extension cable - 5 m	466553.230
	Wiring harness connector cover	ECS0023



ORCHARD SPRAYER



As extremely compact, Bravo 180 for orchard sprayer is the ideal tool for machines featuring small cabins.

Main features

- Special key to recall up to 10 job programs (spray rate/row width/boom configuration).
- Special keys to quickly change row width and required spray rate
- Displayable data: spray rate, speed, calculated pressure, flow rate, distributed amount, tank level, sprayed surface, spraying time, covered distance
- Alarms for: preset spray rate not reached, tank low level
- Temporary increase and reduction of distributed fluid.
- Storage of up to 5 job reports

Technical features

- LED indicators for valve status.
- Inputs for flow rate, speed and pressure signals
- Outputs to control up to 5 boom sections, control valve and main valve
- Selectable language: Italian, English, French, Portuguese, Spanish, Russian, German and Polish.
- Selectable units of measurement: International (ha, km/h), US (Ac, mph) and Unit Canopy Row (l/100m).
- Backlit alphanumeric display - 2 lines x 16 digits
- Power supply: 12Vdc.



Orchard sprayer version

CODE	Ways
467 18231	2
467 18431	4

- Special software for fan orchard sprayer
- Special keys for row width and spray rate
- Operating pressure display

INSTALLATION DIAGRAM AND PACKAGE CONTENT

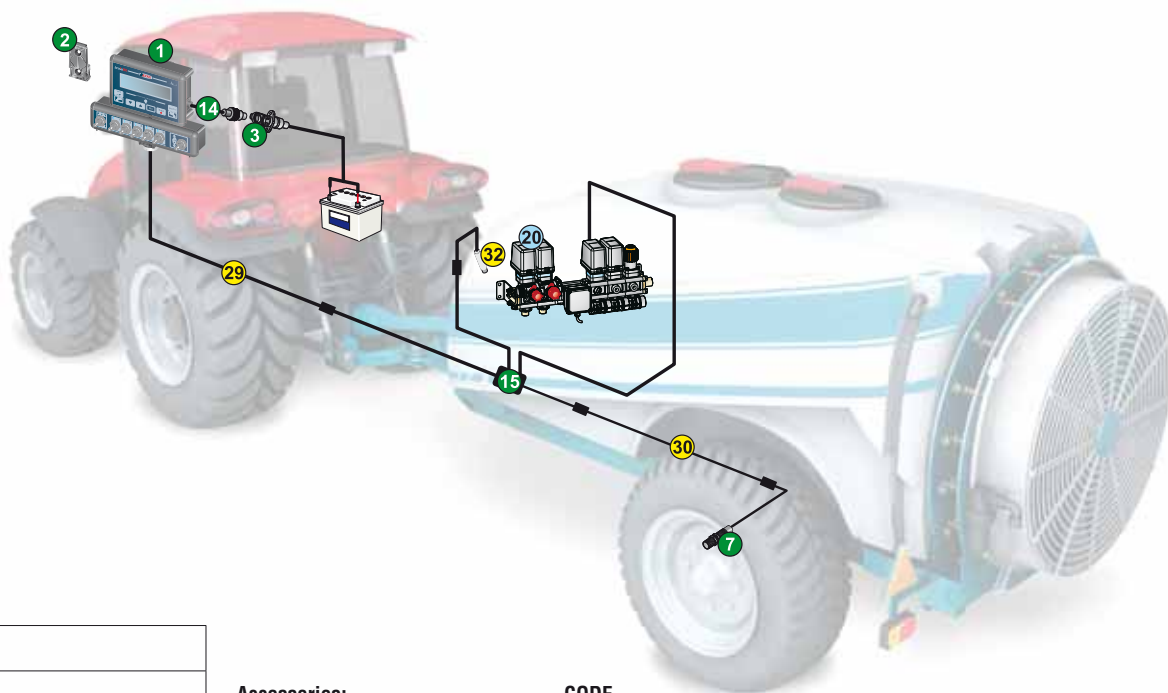

The package includes:

1	Computer
2	Bayonet bracket
3	Panel outlet for power cable
7	Inductive speed sensor with 5 m cable
14	Power cable - 3 m
15	Valve and sensor cable - 4 m
	User's and quick guide

Accessories:

	CODE
29	Extension cable - 3 m 467305.110
	Sensor extension cable - 3 m 466553.220
30	Sensor extension cable - 5 m 466553.230
32	Pressure transducer 466112.200 466112.500
	Wiring harness connector cover ECS0023

To be order separately:

20	Control unit with flow-meter
----	------------------------------



Bravo 130 is a computer especially designed for rows and vineyards. If connected to special ultrasound sensors, which feel tree rows or vine leafage, it will spray the right amount of product only where needed.

Thanks to Bravo 130 crop spraying, once thought to be a difficult task, is now very easy. Spraying process is fully automatic so to save time and remarkably reduce pesticide emissions, resulting in lower costs for the farmer and improved environment and crops safeguard.

- Timed valve closing/opening depending on detected speed
- Extremely lower amounts of chemicals needed
- Lower filling times



CODE	Ways	No. of installable sensors
467 13201*	2	2
467 13401*	4	2/4

* The computer does not include the ultrasound sensors

Features

- Automatic control of section valve opening/closing depending on speed; crop detection via ultrasound sensors.
- Manual spray rate control.
- Spray rate display in litres/ha (GPA) or litres/plant (GPM/plant).
- Displayable data: speed, number of sprayed plants, covered area, spraying time, covered distance, battery voltage.
- Storage of data for 4 field portions: covered area, sprayed product, covered distance.
- Automatic adjustment of solenoid valve opening/closing according to speed.
- Sensor cutting off for special treatments.
- Cable for direct connection to valve and sensor equipped with quick connector.
- Selectable language: Italian, English, Spanish, French, Portuguese and German.
- Selectable units of measurement: International (l/ha) or US (GPA).
- Inputs for flow rate, pressure, speed and sensor signals
- Outputs to control up to 4 boom sections, control valve and main valve
- Backlit display.
- LED indicators for valve status.
- ON/OFF key.
- Large watertight switches for improved ergonomic design.
- Power supply: 12Vdc.

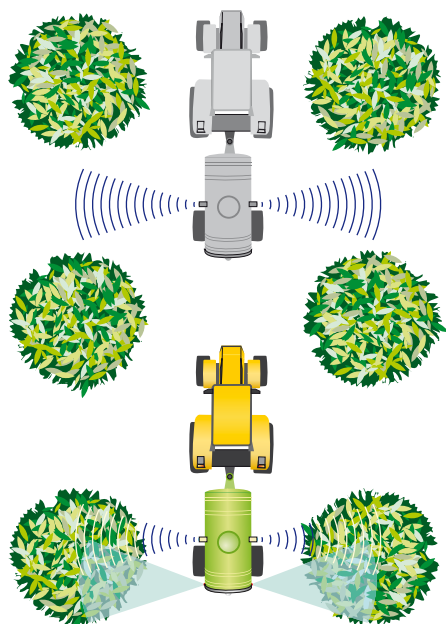

Spraying only to the plants and not to the empty spaces

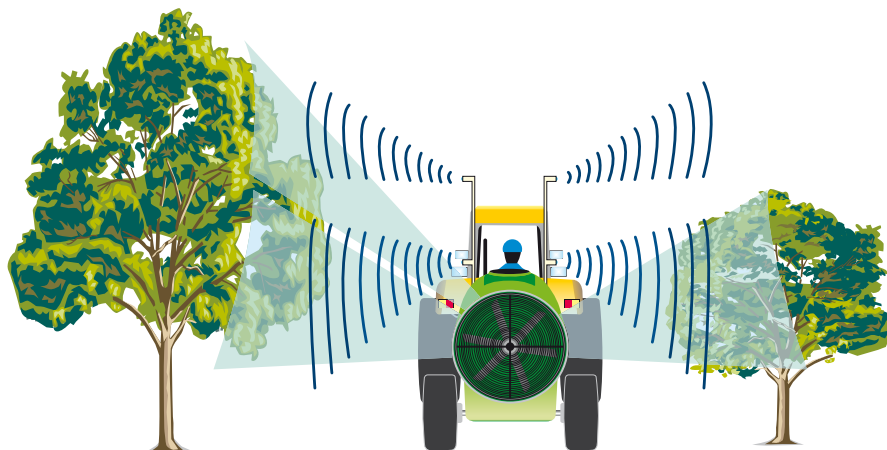

Spraying automatic management according to the height of the plant



FEATURES



CODE	Ways	No. of installable sensors
467 14201*	2	2

* The computer does not include the ultrasound sensors

- User-friendly, handy and cost-effective
- Timed valve closing/opening depending on detected speed
- Extremely lower amounts of chemicals needed

Features

- Automatic control of section valve opening/closing depending on speed; crop detection via ultrasound sensors.
- Displayable data: speed, covered area, number of sprayed trees, ultrasound sensor status.
- Automatic adjustment of solenoid valve opening/closing according to speed.
- Sensor cutting off for special treatments.
- Selectable language: Italian, English, Spanish and Portuguese.
- Selectable units of measurement: International (km/h) or US (mph).
- Operation also without speed sensor by manually setting estimated speed value..
- Outputs to control 2 sprayer sections.
- Backlit display.
- ON/OFF key.
- Power supply: 12Vdc.

bravo130 bravo140 ACCESSORIES



CODE
467 13000.100

Ultrasound sensor

- Max. detection distance: 6 m
- Automatic setting of max. detection distance
- Not affected by dust, dirt or fog
- Power supply 9 ÷ 30 Vdc
- Supplied with retaining ring nut
- Watertight
- Ring nut connector



CODE
467 012

Voltage booster 12-24Vdc

If connected to BRAVO 130 and BRAVO 140 it guarantees a proper ultrasound sensor operation at 24Vdc.



INSTALLATION DIAGRAM AND PACKAGE CONTENT

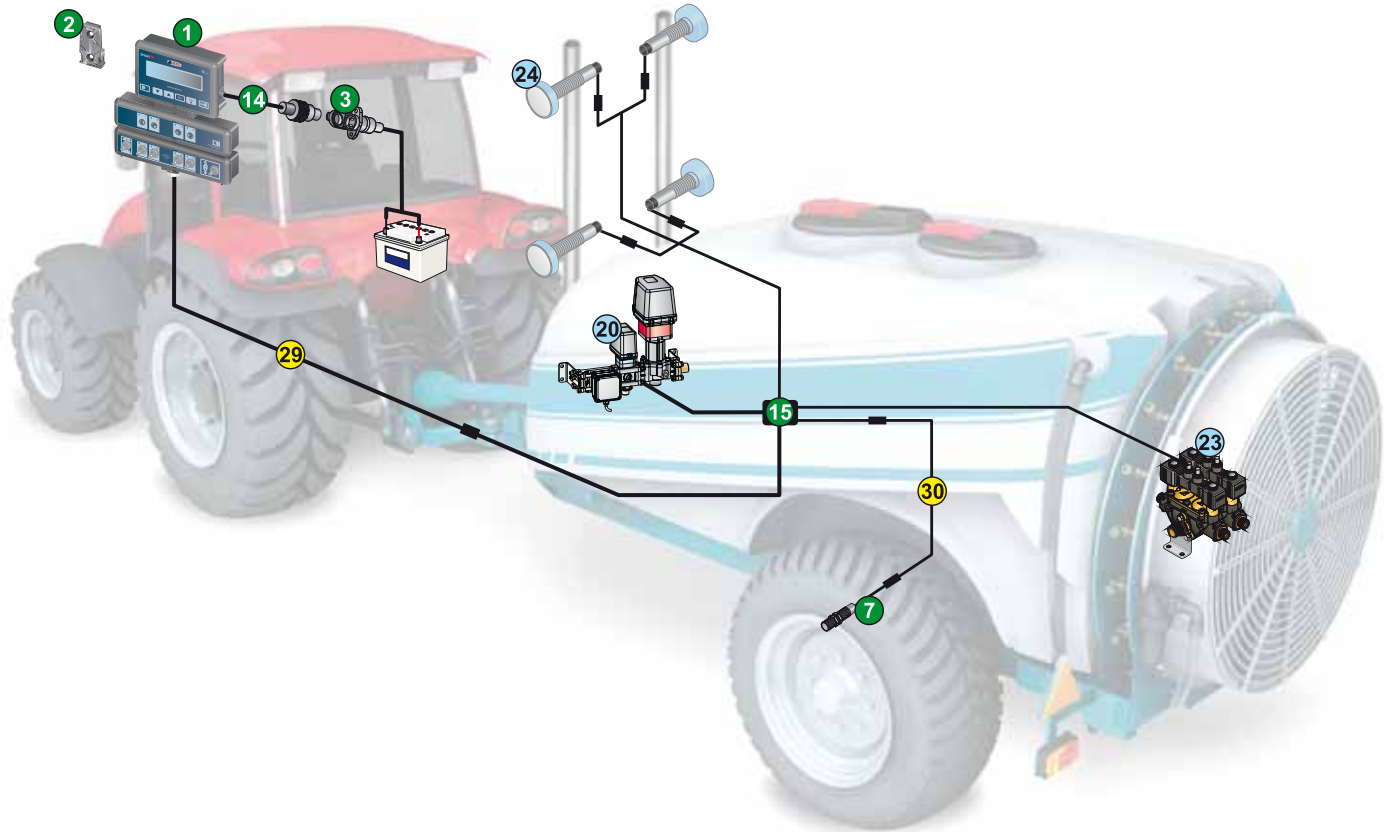

The package includes:

1	Monitor
2	Bayonet bracket
3	Panel outlet for power cable
7	Inductive speed sensor with 5 m cable
14	Power cable - 3 m
15	Cable: 7.5 m for valve and sensor, 9 m for ultrasound sensors
	User's and quick guide

To be order separately:

20	Control unit
23	Solenoid valve unit
24	Ultrasound sensors

Accessories:

		CODE
29	Extension cable - 3 m	467305.110
30	Sensor extension cable - 3 m	466553.220
	Sensor extension cable - 5 m	466553.230
	Wiring harness connector cover	ECS0023

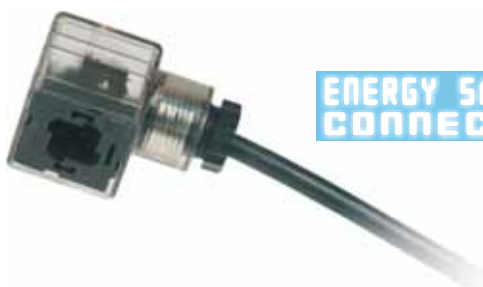

**ENERGY SAVING
CONNECTOR**

BRAVO 130 and BRAVO 140 are equipped with "ENERGY SAVING" connectors for solenoid units, which do not absorb power once the valve has been opened. A LED indicates connector proper operation.

INSTALLATION

INSTALLATION DIAGRAM AND PACKAGE CONTENT

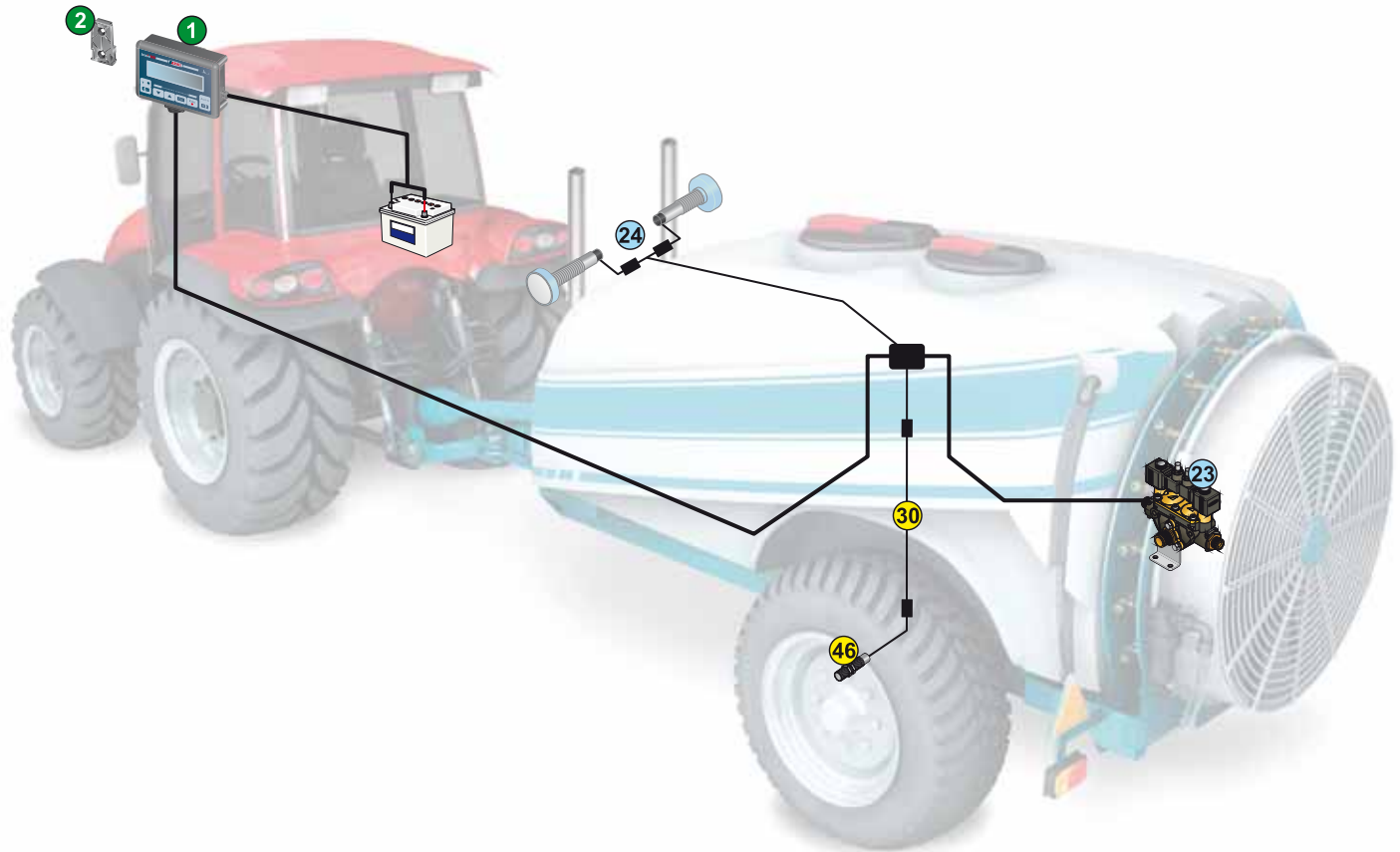

The package includes:

1	Computer complete with cables: power cable - 2 m sensor cable - 9 m valve cable - 7.5 m
2	Bayonet bracket
	User's and quick guide

To be order separately:

23	Solenoid valve unit
24	Ultrasound sensors

Accessories:

		CODE
30	Sensor extension cable - 3 m	466553.220
	Sensor extension cable - 5 m	466553.230
46	Inductive speed sensor with 5 m cable	467100.086



These brand new control units -series 481- with solenoid valves are designed to be connected with BRAVO 130 and BRAVO 140 in all those cases where immediate valve opening and closing are required.

Detailed information and technical data available in ARAG C106 catalogue.



- Different types of sensors can be connected
- Connection port for printer or PC
- Message display in 6 languages

Bravo 120 is a monitor for crop sprayers without automatic distribution control while spraying. Complete and cost-effective, it can be connected to a wide range of sensors to display several data and make job easier even for those machine which do not require advanced control systems while spraying.



CODE	Sections	General	Pressure	Foam marker
467 120	-	-	-	•
467 123	3	•	•	•
467 125	5	•	•	•

Main features

- Displayable data: spray rate, speed, pressure, flow rate, distributed amount, rotation speed, tank level, covered area, spraying time, covered distance, used nozzle, enabled foam marker side and battery voltage
- Alarms for: preset spray rate not reached, tank low level
- Storage of up to 4 job reports
- Job data transfer onto a PC

Technical features

- LED indicators for valve status.
- RS232 serial output
- Inputs for signals of: flow rate, speed, pressure, filling flow rate, revolution counter, Pump Protector.
- Outputs to control up to 5 boom sections, control valve, main valve and foam marker
- Selectable language: Italian, English, Spanish, French, Portuguese and German.
- Selectable units of measurement: International (ha, km/h) or US (Ac, mph)
- Backlit alphanumeric display - 2 lines x 16 digits
- Power supply: 12Vdc.



INSTALLATION DIAGRAM AND PACKAGE CONTENT

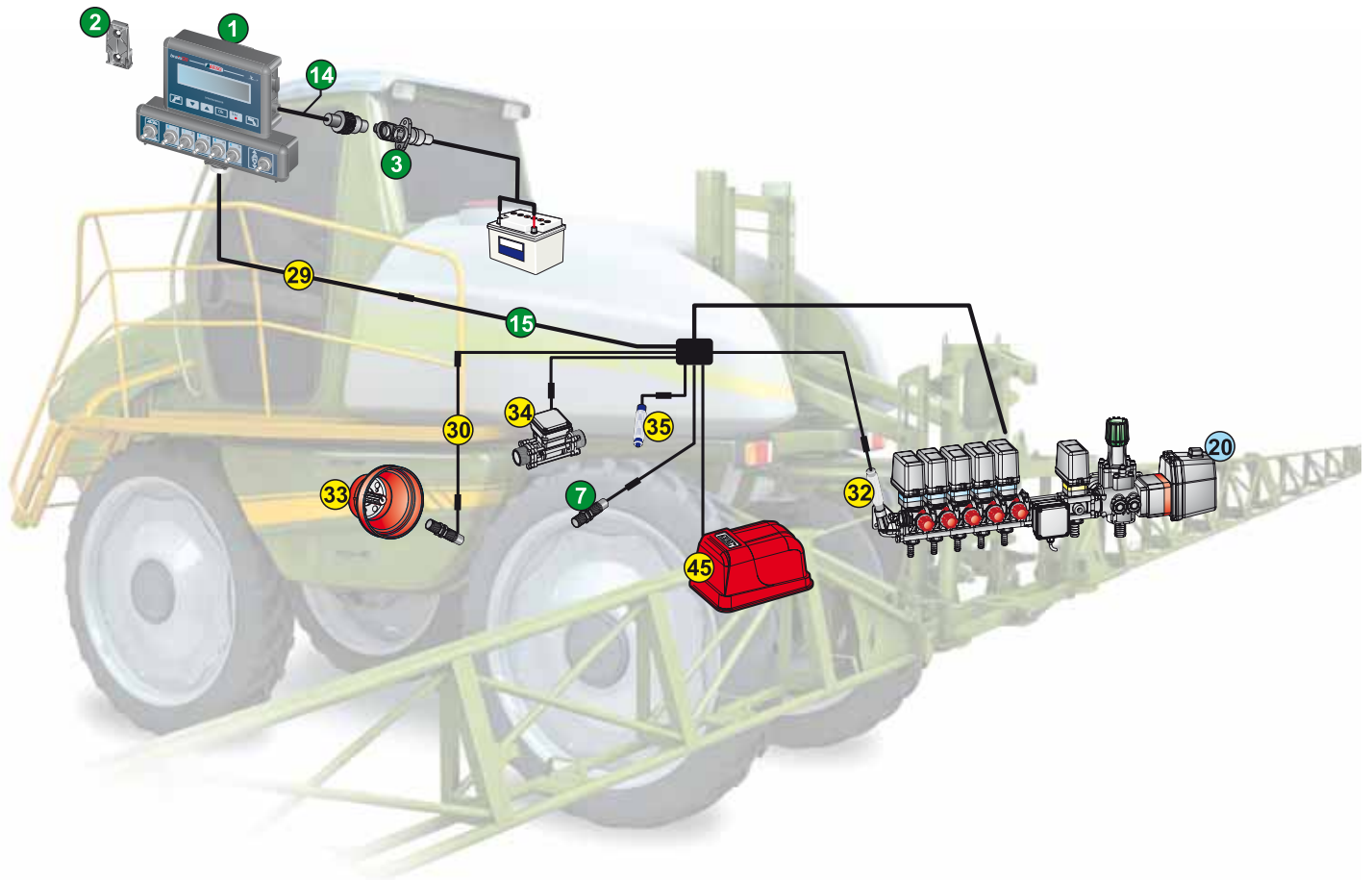

The package includes:

1	Monitor
2	Bayonet bracket
3	Panel outlet for power cable
7	Inductive speed sensor with 5 m cable
14	Power cable - 3 m
15	Valve and sensor connector - 6 m
	User's and quick guide

To be order separately:

20	Control unit with flow-meter
----	------------------------------

Accessories:

	CODE
29	Extension cable 3/5 sect. - 3 m 467305.110
	Sensor extension cable - 3 m 466553.220
30	Sensor extension cable - 5 m 466553.230
32	Pressure transducer 466112.200 466112.500
33	RPM sensor 467100.100 467100.086
34	Filling flow-meter
35	Pump Protector 4664000.100
45	Foam marker 520 005C 520 0052C
	3 and 5 section connector cover ECS0023

CROP SPRAYER



Bravo 110 is a simple and cost-effective monitor which displays basic spraying data while allowing the manual control of up to 5 section valves. Accurate and reliable, it is suitable for small crop sprayers needing an electronic help.

- User-friendly and accurate
- Message display in 6 languages



CODE	Sections	General	Pressure
467 110	-	-	-
467 113	3	•	•
467 115	5	•	•

Main features

- Displayable data: spray rate, speed, flow rate, calculated pressure, distributed amount, tank level, covered area, spraying time, covered distance, used nozzle and battery voltage
- Alarms for: low tank level and fault
- Storage of up to 2 job reports

Technical features

- LED indicators for valve status.
- Inputs for flow rate and speed signals
- Outputs to control up to 5 boom sections, control valve and main valve
- Selectable language: Italian, English, Spanish, French, Portuguese and German.
- Selectable units of measurement: International (ha, km/h) or US (Ac, mph)
- Backlit alphanumeric display - 2 lines x 16 digits
- Power supply: 12Vdc.

INSTALLATION DIAGRAM AND PACKAGE CONTENT

The package includes:

1	Monitor
2	Bayonet bracket
3	Panel outlet for power cable
7	Inductive speed sensor with 5 m cable
14	Power cable - 3 m
15	Valve and sensor cable - 6 m
	User's and quick guide

To be order separately:

20	Control unit with flow-meter
----	------------------------------

Accessories:

		CODE
29	Extension cable 3/5 sect. - 3 m	467305.110
	Sensor extension cable - 3 m	466553.220
30	Sensor extension cable - 5 m	466553.230
	3 and 5 section connector cover	ECS0023

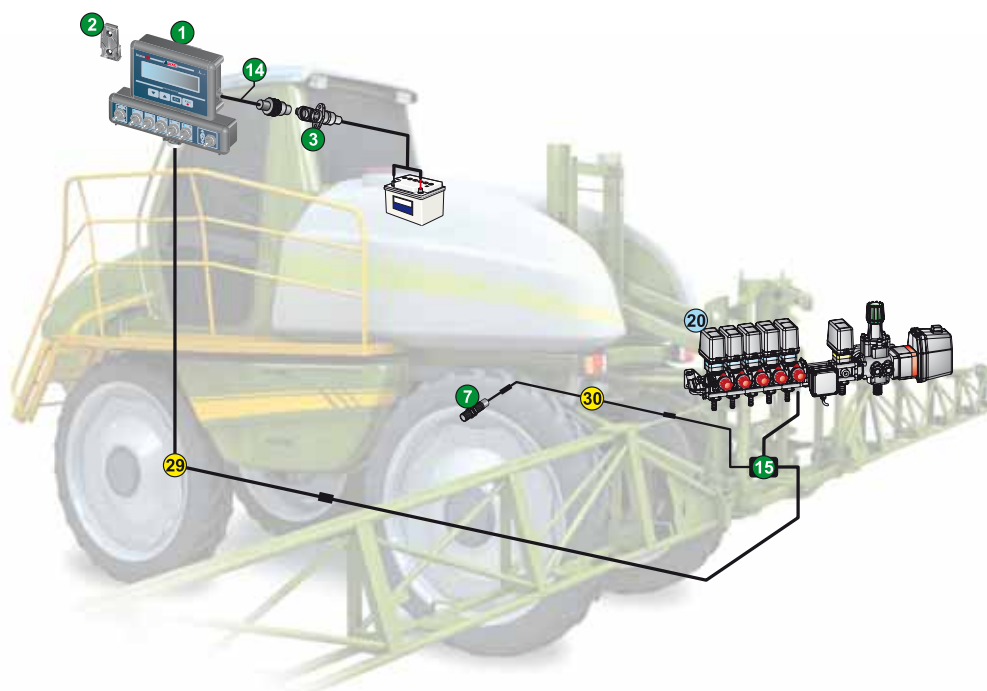



ORCHARD SPRAYER



Available with software for orchard sprayer, Bravo 110 is a cost-effective yet accurate and reliable monitor, especially designed for orchard and vine sprayers. Available with 2 or 4 sections and also in only-monitor version for job data display.

- Operating pressure display
- Easily settable row width
- Message display in 6 languages



CODE	Sections	General	Pressure
467 110A	-	-	-
467 112A	2	•	•
467 114A	4	•	•

Main features

- Storage of 5 row widths which can be quickly recalled.
- Displayable data: spray rate, speed, flow rate, pressure, distributed amount, tank level, covered area, spraying time, covered distance, used sprayer configuration and battery voltage
- Alarms for: low tank level and fault
- Storage of up to 2 job reports

Technical features

- LED indicators for valve status.
- Inputs for flow rate and speed signals
- Outputs to control up to 5 boom sections, control valve, main valve and foam marker
- Selectable language: Italian, English, Spanish, French, Portuguese and German.
- Selectable units of measurement: International (ha, km/h) or US (Ac, mph)
- Backlit alphanumeric display - 2 lines x 16 digits
- Power supply: 12Vdc.

INSTALLATION DIAGRAM AND PACKAGE CONTENT

The package includes:

1	Monitor
2	Bayonet bracket
3	Panel outlet for power cable
7	Inductive speed sensor with 5 m cable
14	Power cable - 3 m
15	Valve and sensor cable - 6 m
	User's and quick guide

To be order separately:

20	Control unit with flow-meter
----	------------------------------

Accessories:

CODE

29	Extension cable 3/5 sect. - 3 m	467305.110
30	Sensor extension cable - 3 m	466553.220
	Sensor extension cable - 5 m	466553.230
32	Pressure transducer	466112.200
		466112.500
	3 and 5 section connector cover	ECS0023

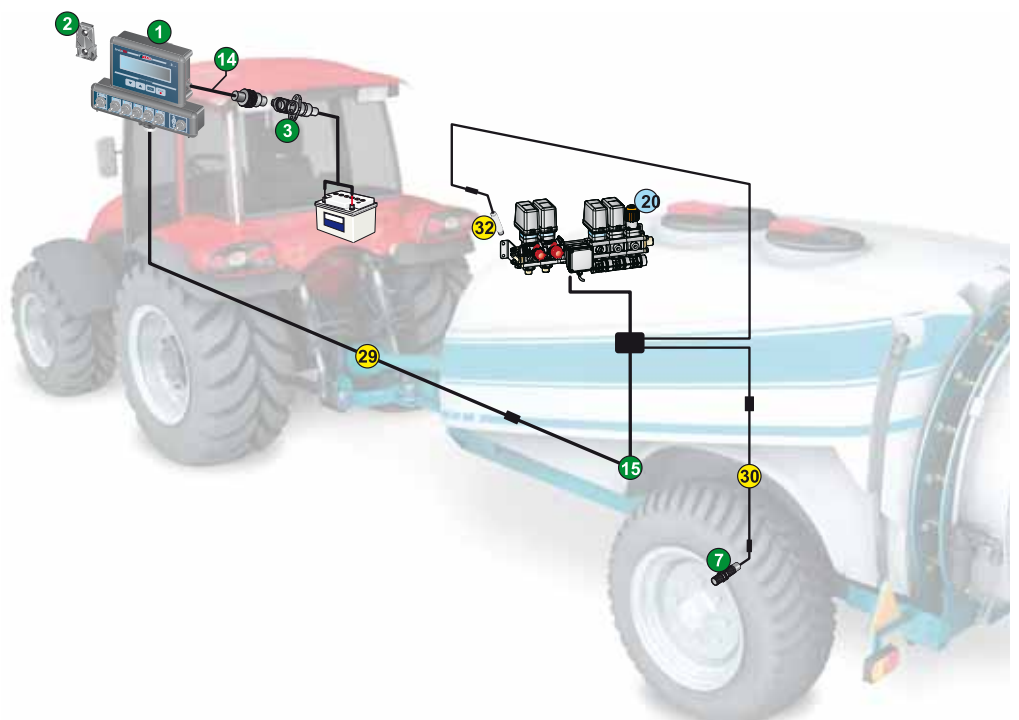



Digiblock 2 is a compact, hi-precision and cost-effective multifunction display. Developed in different versions, it can be connected to several sensors to display many job data.

- Backlit display
- Bayonet retainer
- Waterproof



DIGIBLOCK2 FLOW RATE

- Flow rate display: litres/min-gallons/min
- Distributed fluid display: litres-gallons
- Reset of total distributed fluid counter

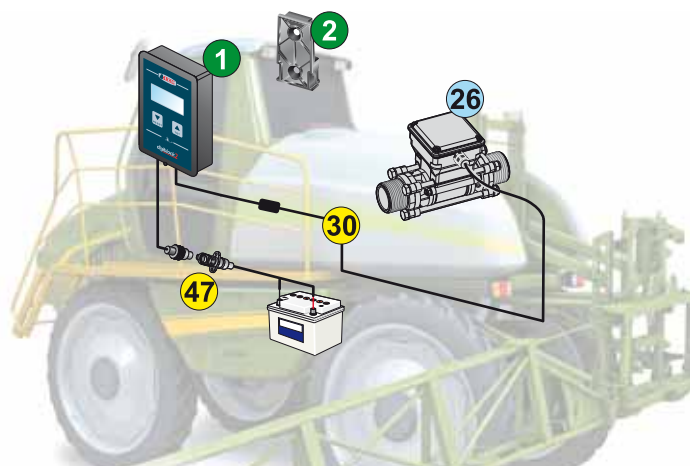

CODE	Description
467 060L	FLOW RATE

DIGIBLOCK2 AREA MEASUREMENT

- Covered area measurement: ha-acres
- Reset of total covered area counter
- Speed display: Km/h-Miles/h

DIGIBLOCK2 SPEED

- Speed display: Km/h-Mph
- Covered distance display: Km-Miles
- Reset of total covered distance counter

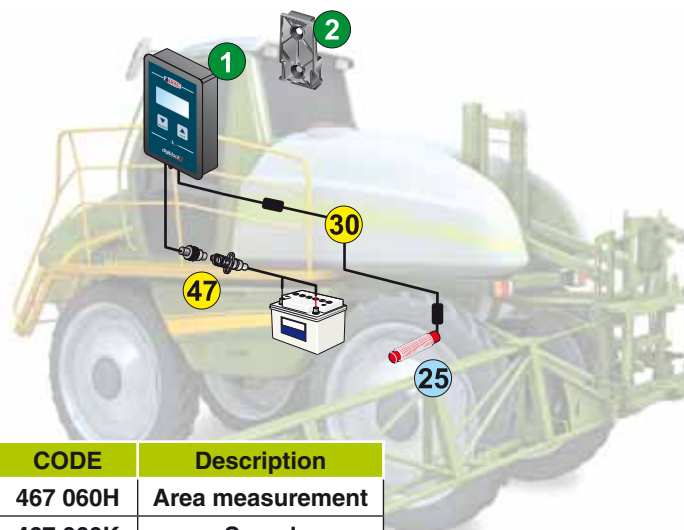

CODE	Description
467 060H	Area measurement
467 060K	Speed

DIGIBLOCK2 SPRAY RATE/SPEED

- Display of instant distribution value: litres/hectare-gallons/acre (GPA)
- Speed display: Km/h-Miles/h

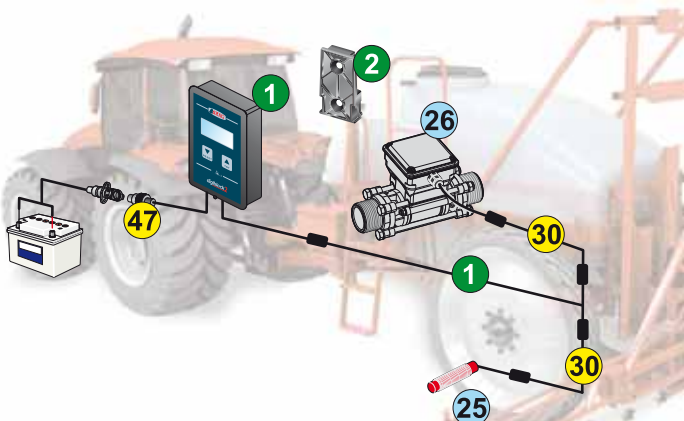

CODE	Description
467 060LH	Spray rate/speed

DIGIBLOCK2 REVOLUTION COUNTER

- Display of shaft rotation speed: rotations/min.

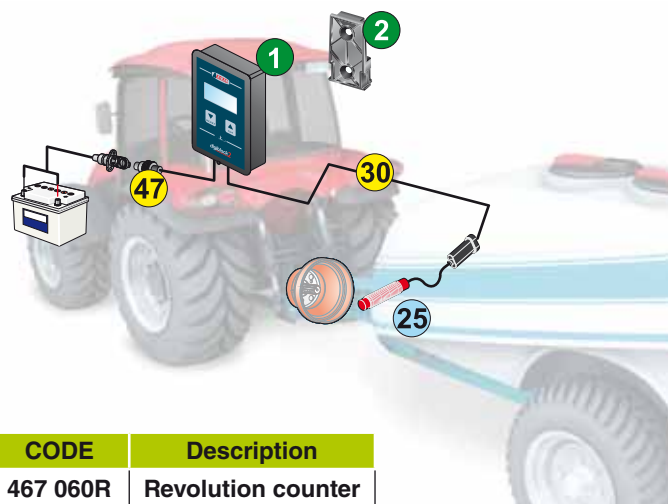

CODE	Description
467 060R	Revolution counter



MULTIFUNCTION DISPLAY

The package includes:

1	Display complete with cables (2 m power cable and 3 m sensor cable).
	3 m cable for two sensors (<i>Model 467060LH only</i>).
2	Bayonet bracket
	User's and quick guide

Accessories:

		CODE
30	Sensor extension cable - 3 m	466553.220
	Sensor extension - 5 m	466553.230
47	Power outlet and plug	466001

To be order separately:

		CODE
25	Magnetic speed sensor	467100.100
	Inductive speed sensor	467100.086
26	ORION flow-meter	

Digiblock 2S is a special display for filling systems. It can display tank filling level and automatically stop filling once set amount has been reached. It can be directly connected to the filling pump and automatically control it via the supplied module.

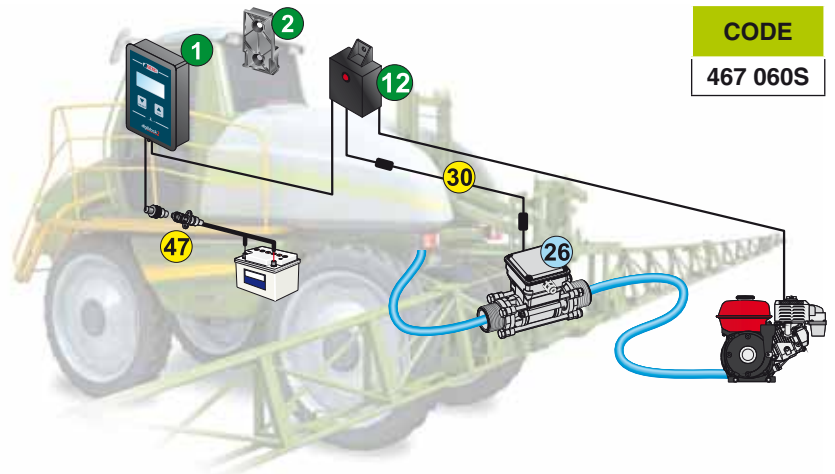

CODE

467 060S

Digiblock 2V can be directly connected to BRAVO 300S computer to which it will send tank filling data and a solenoid valve to automatically stop the filling procedure once the preset value has been reached.

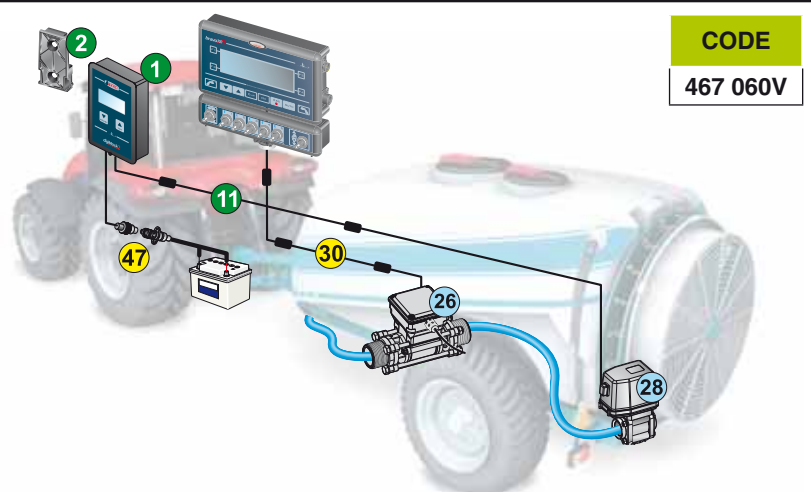

CODE

467 060V

The package includes:

1	Display complete with cables - 3 m power cable
2	Bayonet bracket
11	Valve closing kit (<i>for 467060V only</i>)
12	Pump stop kit (<i>for 467060S only</i>) with 3 m cable
	User's and quick guide

To be order separately:

26	ORION flow-meter	
28	Ball solenoid valve series 453	Cat.C106

Accessories:

		CODE
30	Sensor extension cable - 3 m	466553.220
	Sensor extension cable - 5 m	466553.230
47	Power outlet and plug	466001

ELECTROMAGNETIC FLOW-METER



Benefits

- Free from mechanical moving parts
- Insensitive to fluid thickness and viscosity
- Low sensitivity to swirl
- High precision
- Reduced maintenance

Features

- Instant flow rate display
- Display of supplied fluid or fluid filled in the tank
- Programmable fluid amount to be filled in the tank
- Reset of total supplied fluid counter
- Unit of measurement in litres or US gallons
- Typical error 0.5% - MAX 1 % (full scale)
- Operating pressure up to 40 bar
- Pulse output 0-12 Vdc
- Max. absorption 300 mA
- Signal emitted only when the fluid is flowing
- Available with threaded fiberglass-reinforced nylon connectors (20 bar) or brass connectors (40 bar)
- Parts in contact with fluid made of stainless steel 316 and polypropylene



CODE					F BSP	Inner openings mm	Pulses	
	lt/1'	US GPM	bar	PSI			pls/l	pls/GAL
4621BA01313	0,5÷10	0.13÷2.6	20	290	G 3/4	5	6000	22710
4621BA03333	0,5÷10	0.13÷2.6	40	580	G 3/4	5	6000	22710
4621BA11313	1÷20	0.3÷5	20	290	G 3/4	7	3000	11355
4621BA13333	1÷20	0.3÷5	40	580	G 3/4	7	3000	11355
4621BA21313	2,5÷50	0.6÷13	20	290	G 3/4	10	1200	4542
4621BA23333	2,5÷50	0.6÷13	40	580	G 3/4	10	1200	4542
4621BA31414	5÷100	1.3÷26	20	290	G 1	14	600	2271
4621BA33434	5÷100	1.3÷26	40	580	G 1	14	600	2271
4621BA41414	10÷200	2.6÷53	20	290	G 1	18,5	300	1135
4621BA43434	10÷200	2.6÷53	40	580	G 1	18,5	300	1135
4621BA41515	10÷200	2.6÷53	20	290	G 1 1/4	18,5	300	1135
4622BA51616	20÷400	5÷106	20	290	G 1 1/2	28	150	568
4622BA61616	30÷600	8÷158	20	290	G 1 1/2	28	100	378
4622BA61717	30÷600	8÷158	20	290	G 2	28	100	378

Power cable



CODE	Poles	mt	For
4622BA50000.100	4	3	VISUAL FLOW



ELECTROMAGNETIC FLOW-METER

Benefits

- Free from mechanical moving parts
- Insensitive to fluid thickness and viscosity
- Low sensitivity to swirl
- High precision
- Reduced maintenance

Features

- Typical error 0.5% - MAX 1 % (full scale)
- Operating pressure up to 40 bar
- Pulse output 0-12 Vdc
- Max. absorption 300 mA
- Signal emitted only when the fluid is flowing
- Available with threaded or flanged connectors
Threaded fiberglass-reinforced nylon connectors (20 bar) or brass connectors (40 bar)
- Parts in contact with fluid made of stainless steel 316 and polypropylene



CODE					Inner openings mm	Pulses		For valves
	lt/1'	US GPM	bar	PSI		pls/l	pls/GAL	
4621AA00000	0,5÷10	0.13÷2.6	40	580	5	6000	22710	Series 463
4621AA10000	1÷20	0.3÷5	40	580	7	3000	11355	
4621AA20000	2,5÷50	0.6÷13	40	580	10	1200	4542	
4621AA30000	5÷100	1.3÷26	40	580	14	600	2271	
4621AA40000	10÷200	2.6÷53	40	580	18,5	300	1135	
4622AA40000	10÷200	2.6÷53	20	290	18,5	300	1135	Series 473
4622AA50000	20÷400	5÷106	20	290	28	150	568	
4622AA60000	30÷600	8÷158	20	290	28	100	378	



CODE					F BSP	Inner openings mm	Pulses	
	lt/1'	US GPM	bar	PSI			pls/l	pls/GAL
4621AA01313	0,5÷10	0.13÷2.6	20	290	G 3/4	5	6000	22710
4621AA03333	0,5÷10	0.13÷2.6	40	580	G 3/4	5	6000	22710
4621AA11313	1÷20	0.3÷5	20	290	G 3/4	7	3000	11355
4621AA13333	1÷20	0.3÷5	40	580	G 3/4	7	3000	11355
4621AA21313	2,5÷50	0.6÷13	20	290	G 3/4	10	1200	4542
4621AA23333	2,5÷50	0.6÷13	40	580	G 3/4	10	1200	4542
4621AA31414	5÷100	1.3÷26	20	290	G 1	14	600	2271
4621AA33434	5÷100	1.3÷26	40	580	G 1	14	600	2271
4621AA41414	10÷200	2.6÷53	20	290	G 1	18,5	300	1135
4621AA43434	10÷200	2.6÷53	40	580	G 1	18,5	300	1135
4621AA41515	10÷200	2.6÷53	20	290	G 1 1/4	18,5	300	1135
4622AA51515	20÷400	5÷106	20	290	G 1 1/4	28	150	568
4622AA51616	20÷400	5÷106	20	290	G 1 1/2	28	150	568
4622AA61616	30÷600	8÷158	20	290	G 1 1/2	28	100	378
4622AA61717	30÷600	8÷158	20	290	G 2	28	100	378

Power cable



CODE	Poles	mt	For
4621AA10000.100	3	3	ORION



Market trend has pushed operators and manufacturers to develop improved systems which can meet requirements of top job safety and total machine control. ARAG is pleased to introduce their new line of products for camera-based vision systems for our Precision Farming range. Cameras can be used while reversing or to inspect parts hardly visible while driving.



LCD screen

Main features

- Adjustable bracket
- Aluminium case
- Sunshade
- Control keys for: video channel, volume and control menu

Technical features

- Audio output
- Inputs for 3 cameras
- 5.6" TFT colour display - 960x324 pixels
- Power supply: 12-32 Vdc.

CODE

467 00101

Video camera

Main features

- Infrared night vision
- Adjustable bracket
- Selector for direct or symmetrical vision

Technical features

- CCD 1/3" colour sensor - 512x582 pixels
- Vision angle: 120°
- Cable - 10 m
- Power supply: 12Vdc.



CODE

467 00100

SIMULATOR

BRAVO DSB is an electronic simulation and demo /diagnostic tool for BRAVO computers. This device can either simulate the operation of a sprayer equipped with BRAVO if directly connected with the computer or show a didactic demo on system operation. If Bravo DSB is connected to a spraying system running, it will make a complete system diagnosis.

- Aluminium case
- **Universal power supply** (with Europe plug)
- **Adaptor kit:**
 - Standard outlet type 112/CEE III
 - USA plug
 - UK plug
 - AUS plug
- 5-section "T" wiring



CODE
467 003



Connection example of BRAVO DSB for diagnostic purposes

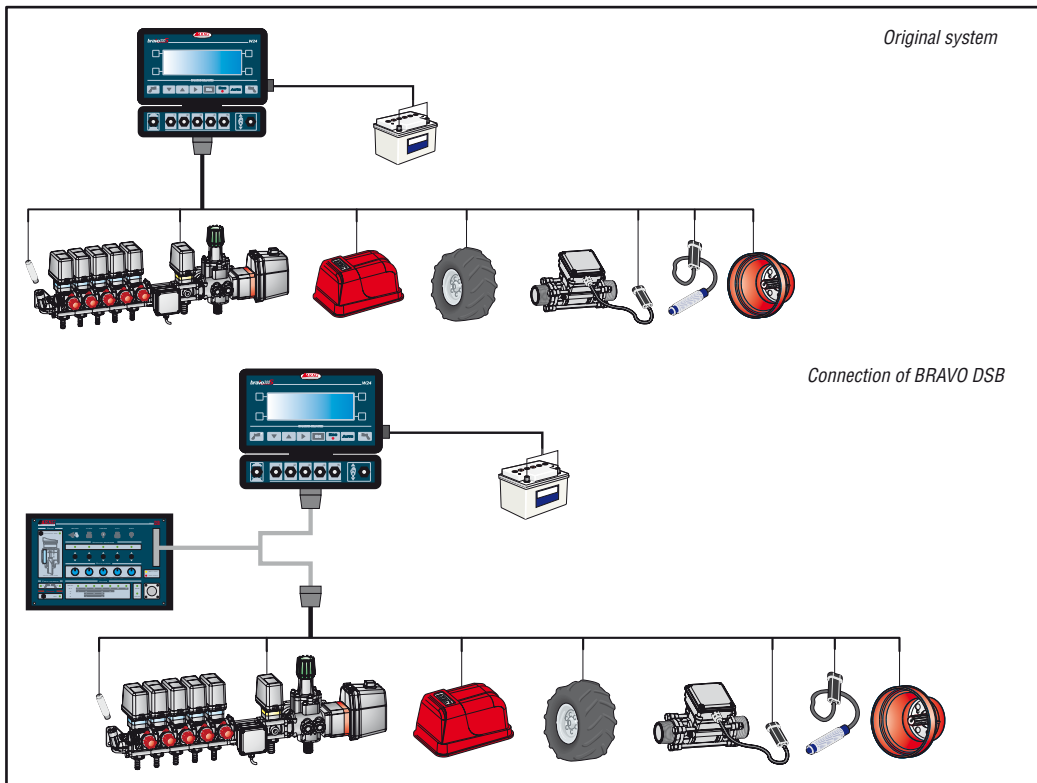

Cables

To be ordered separately

For	CODE
BRAVO 120 (Part no. 467120) BRAVO 110 (Part no. 467110) (Part no. 467110A)	467 003.101
BRAVO 300S RCU (Part no. 467 32XX1) (Part no. 467 33XX1)	467 003.102
BRAVO 300S (Part no. 467 30701) (Part no. 467 31701)	467 003.104

For all other BRAVO computer and monitor models, use the cable supplied with BRAVO DSB.

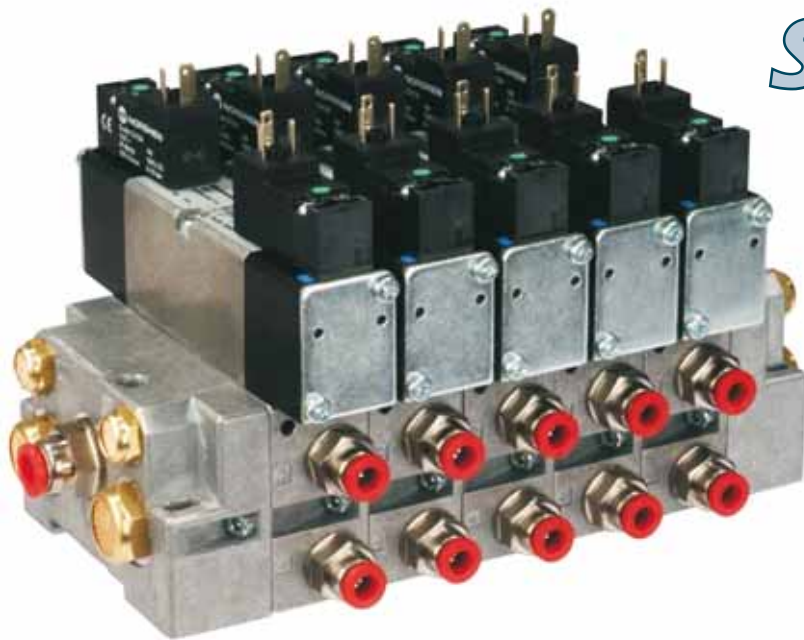

sele
JET

Air-operated unit for SELEJET nozzle holder

Main features

- Units with 5 and 7 air-operated valves
- Electric valves with low absorption solenoid
- Twin-pocket technology
- Manual control
- Die-cast aluminium valve bodies and underbase
- Compact

Technical features

- Power supply: 12 Vdc
- Solenoid absorption: 1 W
- Operating pressure: 3÷10 bar
- Flow rate: 1100 l/min
- 8 mm air input line fitting
- 6 mm air output line fittings

new

CODE	Ways
NSPI 4045200	5
NSPI 4045300	7

Inclination sensor



CODE
467 008

- It corrects GPS positioning error due to machine inclination -even 2 m on steep slopes- while spraying.
- It can be connected to Sirio or Skipper
- Watertight aluminium case with integrated fixing holes
- It can be installed in any place onto the machine
- Extremely insensitive to vibrations

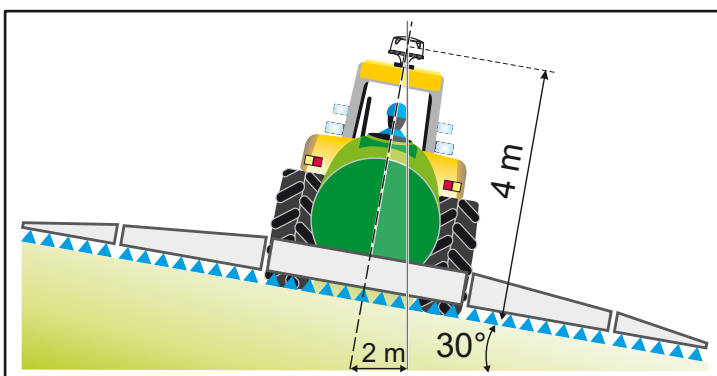

Suction cup support for SKIPPER and BRAVO

- Strong
- Twin ball joint for any kind of position
- Vibration damped
- Integrated bracket connection

CODE
467 040.650





Pressure transducer



CODE	Type
466 112.200	0-20 bar / 0-290 PSI
466 112.500	0-50 bar / 0-720 PSI

Magnetic speed detector kit

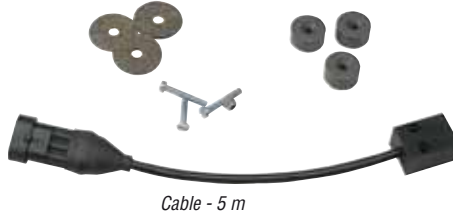

Cable - 5 m

CODE
467 100.100

Inductive speed detector



Cable - 5 m

CODE
467 100.086

Extension cables



CODE	Description	Poles
467 305.110	Extension cable 3/5 sect. - 3 m	23
467 307.110	Extension cable 7 sect. - 3 m	28



CODE	Description	Poles
466 553.220	Sensor extension cable - 3 m	3
466 553.230	Sensor extension cable - 5 m	3

Covers for BRAVO computer and monitor harness connectors

They seal harness connectors when not connected to the computer thus preventing them to become oxidised.

CODE	Computer	Poles
ECS 0023	Bravo 300S/1xx up to 5 sections	23
ECS 0024	Bravo 300S/120xx up to 7 sections	28



Power sockets-plugs



CODE	Type
466 111	2 pin



CODE	Type
466 001	3 pin

Cigarette lighter plug



CODE
ECS0056



skipper navigator manager

SKIPPER NAVIGATOR MANAGER is a software for personal computer* which allows the user to display, complete and print finished job reports with the help of Skipper.

Supplied onto 512M Byte Pen Drive for downloading data from Skipper, it allows:

- Linear and extensive measurements, even of polygonal areas
- Input of point of interests with notes
- Map magnification for detailed job analysis
- Video replay of performed spraying
- Graphic and numeric customised report print of completed job



CODE

467 013

*Minimal requirements: Windows XP, min. 512 Mbyte RAM, 10 Mb free on hard disk

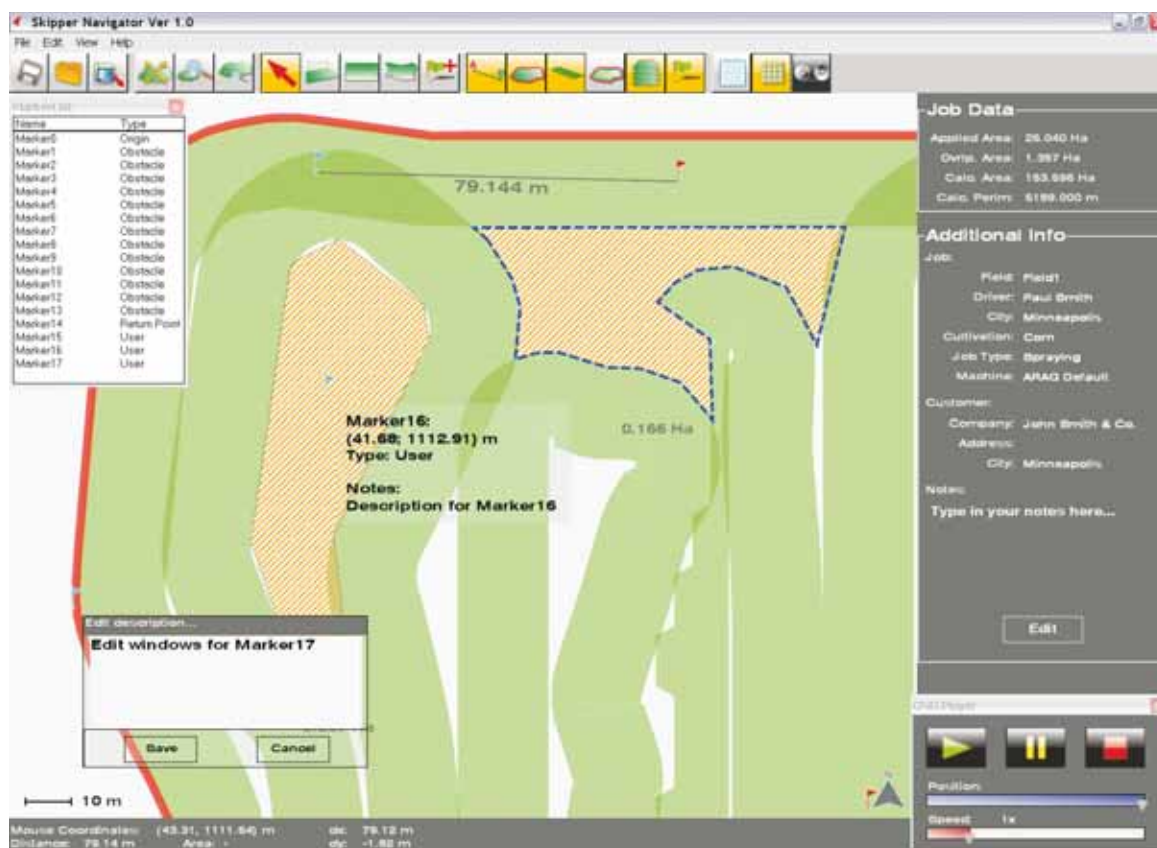

USB SD memory card reader

CODE

467 00110



SPARE PARTS

PRODUCT PART NUMBERS

46742501 - 46742701 - 46742511 - 46742711 - 46742721 - 46747501 - 46747701 - 46747511 - 46747711 - 46747721 - 46742D01

- 46742D00.960 (8 ÷ 13 vie / valves - Sequenziale / Sequential)
- 46742500.960 (5 vie / valves)
- 46742700.960 (7 vie / valves)
- 46742510.960 (5 vie / valves - 7 Funzioni idrauliche / Hydraulic functions)
- 46742710.960 (7 vie / valves - 7 Funzioni idrauliche / Hydraulic functions)
- 46742720.960 (7 vie / valves - 9 Funzioni idrauliche / Hydraulic functions)
- 46747500.960 (5 vie / valves - SELEJET)
- 46747700.960 (7 vie / valves - SELEJET)
- 46747510.960 (5 vie / valves - 7 Funzioni idrauliche / Hydraulic functions - SELEJET)
- 46747710.960 (7 vie / valves - 7 Funzioni idrauliche / Hydraulic functions - SELEJET)
- 46747720.960 (7 vie / valves - 9 Funzioni idrauliche / Hydraulic functions - SELEJET)

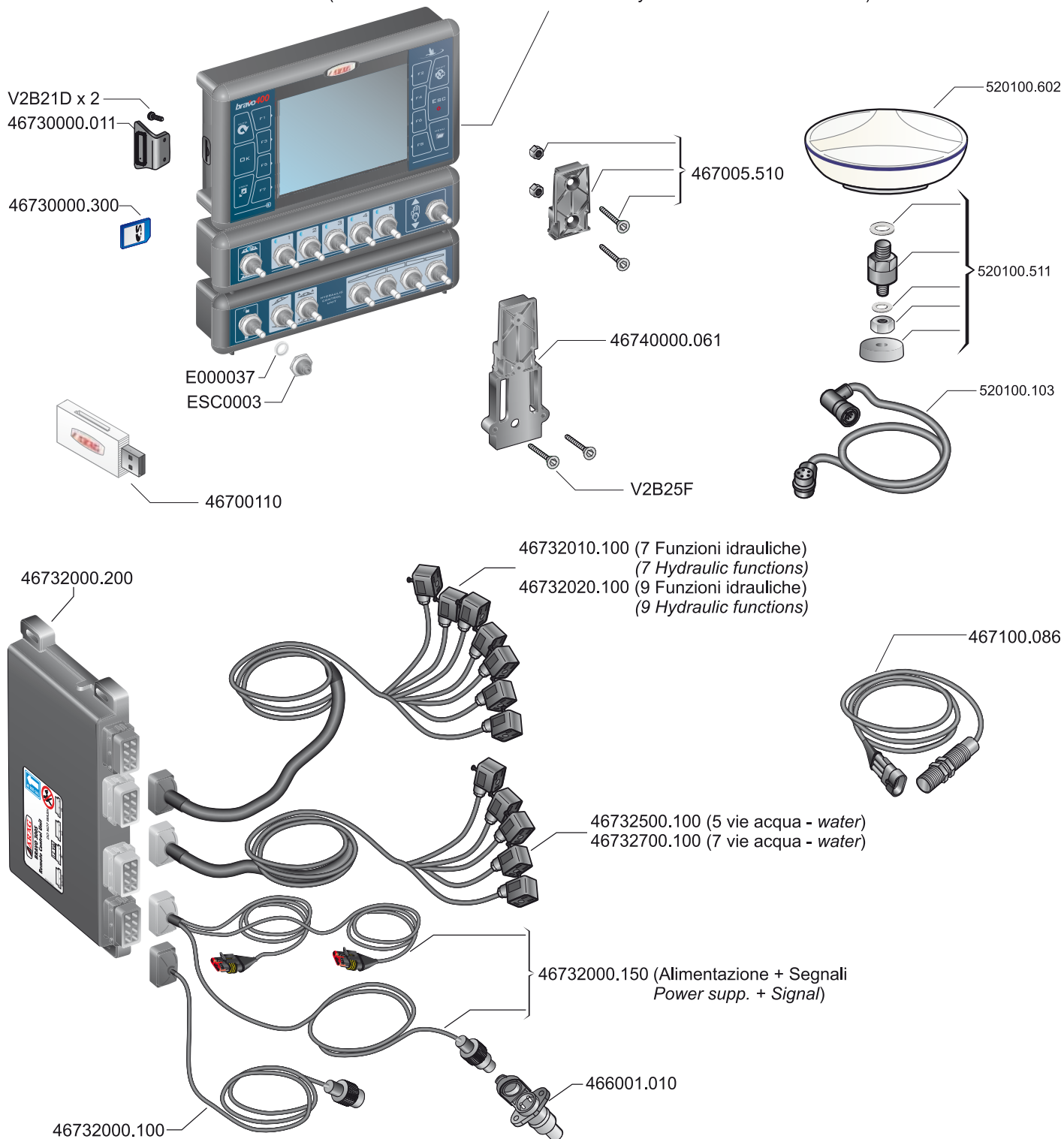



PRODUCT PART NUMBERS

467070

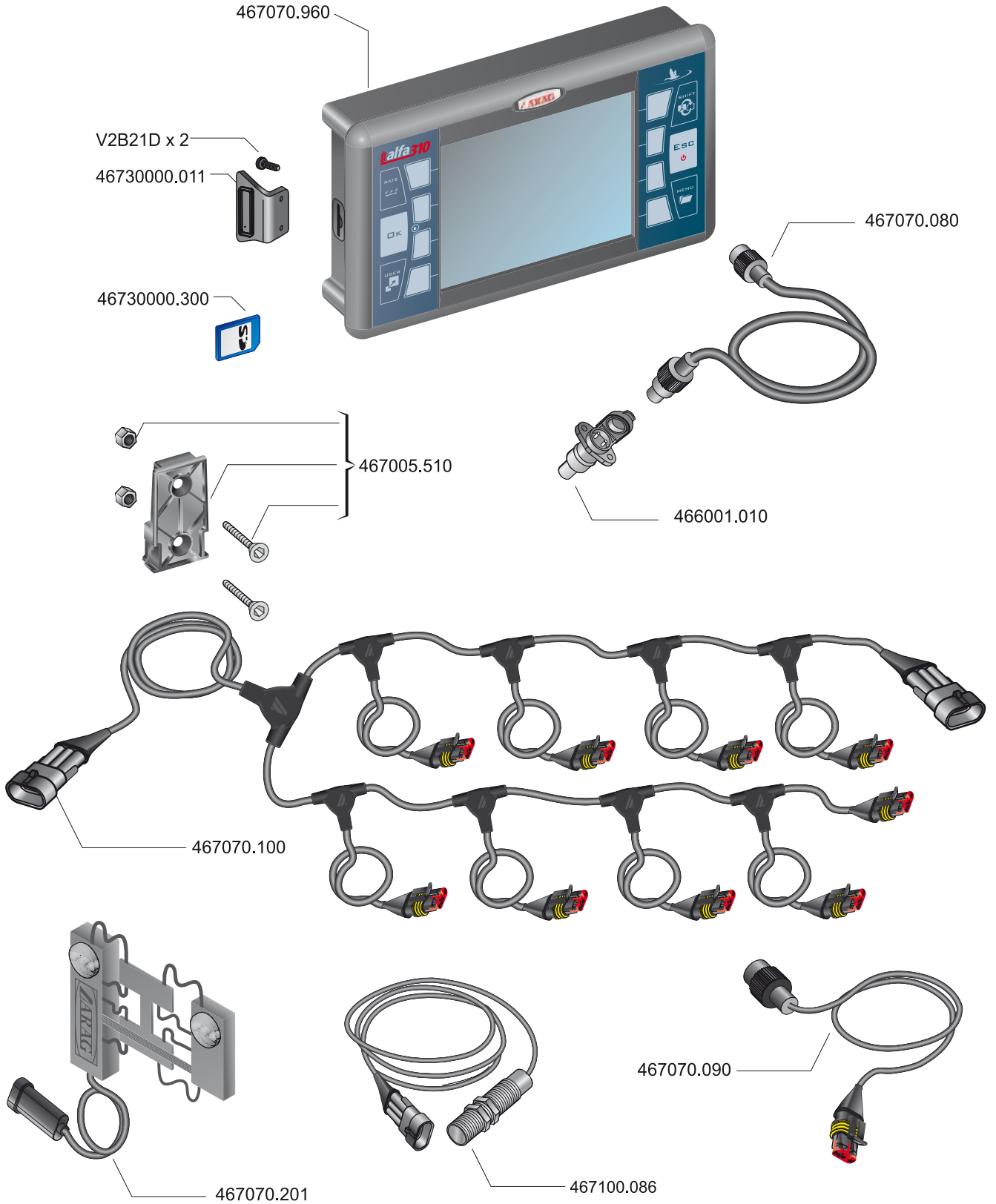

PRODUCT PART NUMBERS

467031

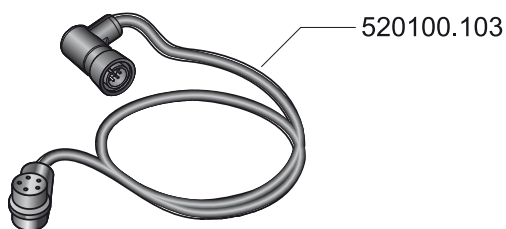
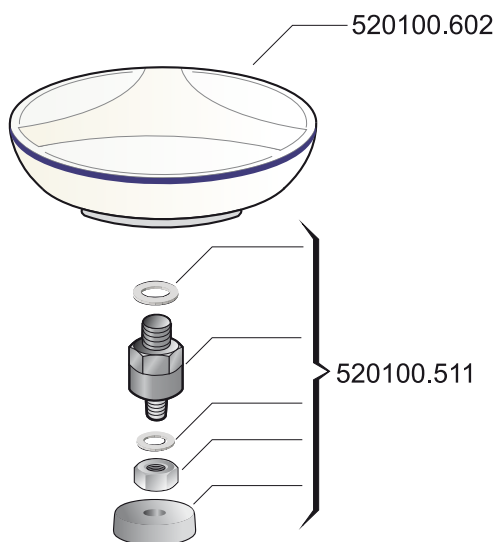
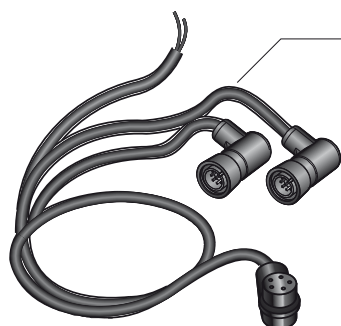
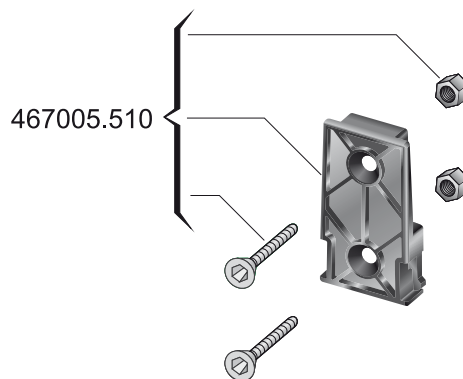



PRODUCT PART NUMBERS

467020

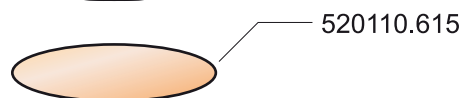
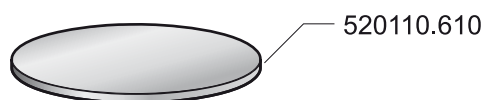
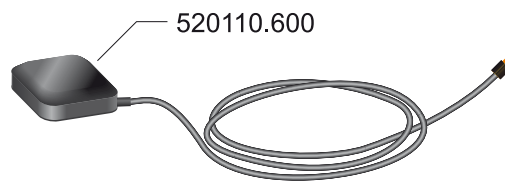
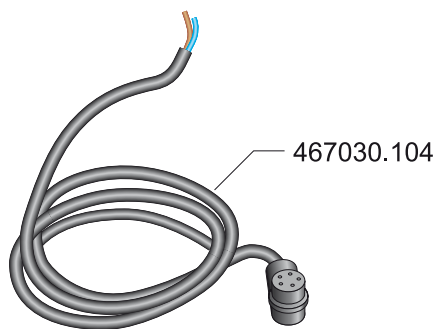
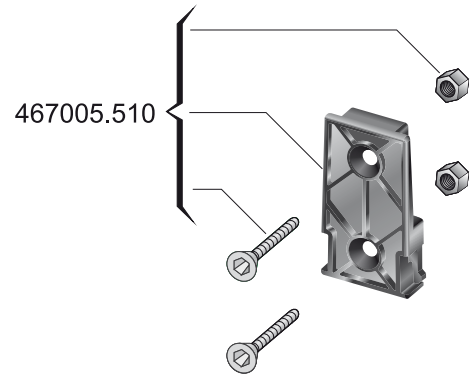

PRODUCT PART NUMBERS



520110

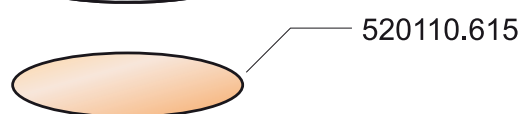
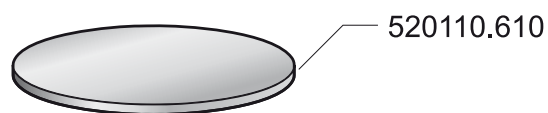
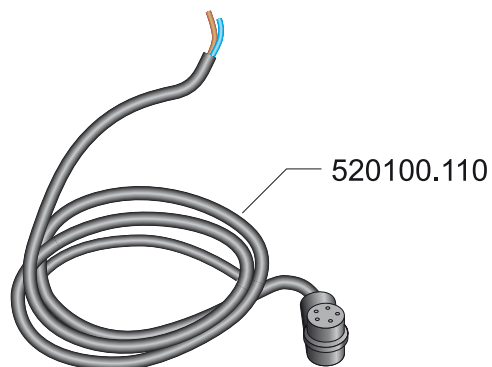
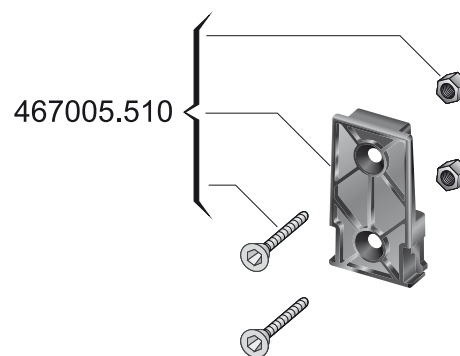
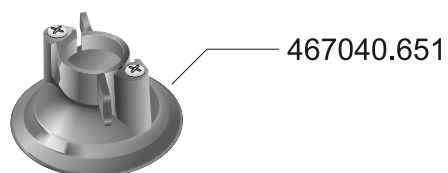
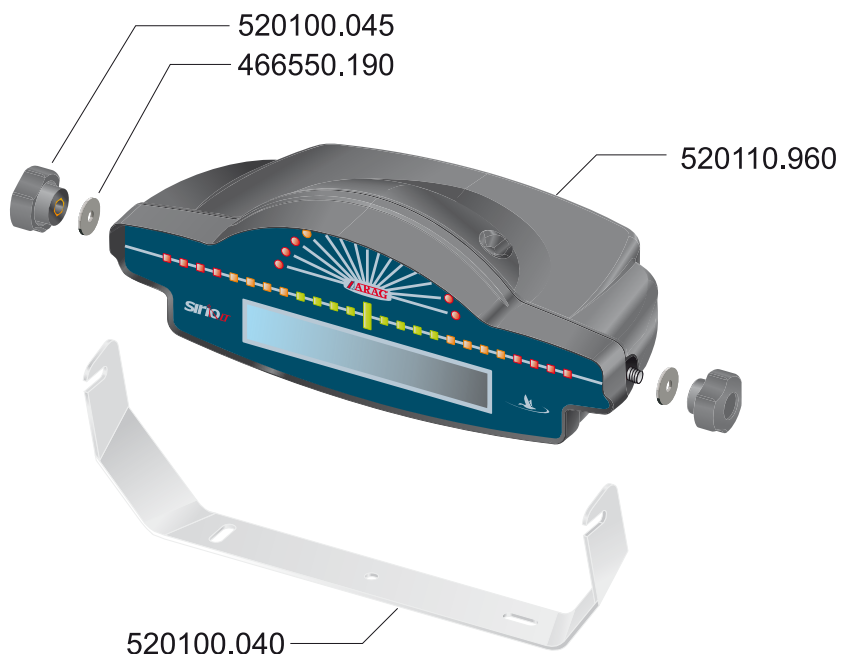



PRODUCT PART NUMBERS

46732501 - 46732701 - 46732511 - 46732711 - 46732721 - 46732D01 - 46732D11 - 46732D21 - 46733511 - 46733711 - 46733721

- 46732500.960 (5 vie / valves)
- 46732700.960 (7 vie / valves)
- 46732510.960 (5 vie / valves - 7 Funzioni idrauliche / Hydraulic functions)
- 46732710.960 (7 vie / valves - 7 Funzioni idrauliche / Hydraulic functions)
- 46732720.960 (7 vie / valves - 9 Funzioni idrauliche / Hydraulic functions)
- 46733510.960 (5 vie / valves - 7 Funzioni idrauliche / Hydraulic functions - Multifilare / Multirow)
- 46733710.960 (7 vie / valves - 7 Funzioni idrauliche / Hydraulic functions - Multifilare / Multirow)
- 46733720.960 (7 vie / valves - 9 Funzioni idrauliche / Hydraulic functions - Multifilare / Multirow)
- 46732D00.960 (13 vie / valves - Sequenziale / Sequential)
- 46732D10.960 (13 vie / valves - 7 Funzioni idrauliche / Hydraulic functions - Sequenziale / Sequential)
- 46732D20.960 (13 vie / valves - 9 Funzioni idrauliche / Hydraulic functions - Sequenziale / Sequential)

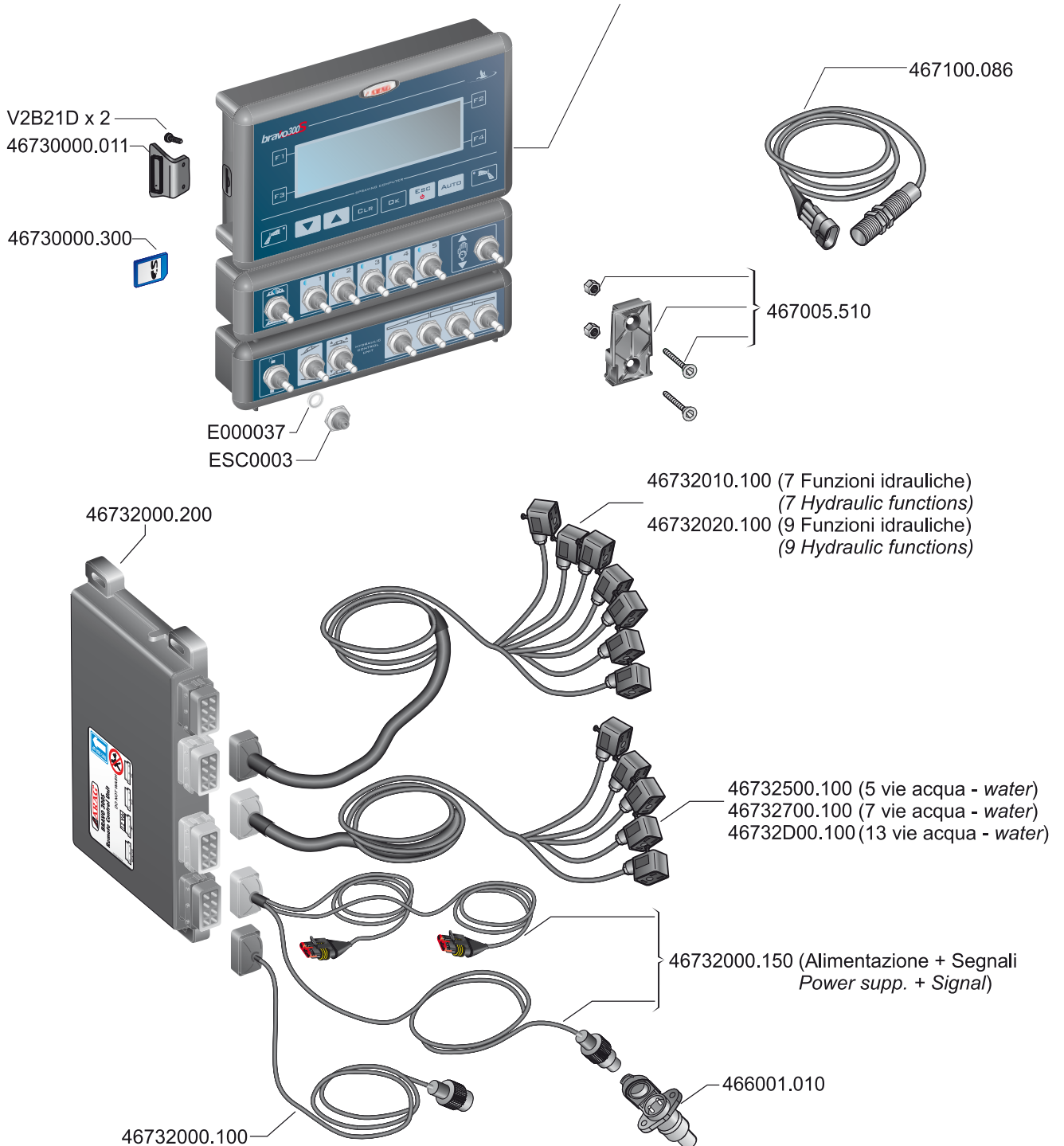

PRODUCT PART NUMBERS

46730401 - 46730501 - 46730701 - 46731401 - 46731501 - 46731701 - 46734401 - 46736501 - 46736701

- 46730400.960 (4 vie / 4 valves)
- 46730500.960 (5 vie / 5 valves)
- 46730700.960 (7 vie / 7 valves)
- 46731400.960 (4 vie / 4 valves - Multifilare / Multirow)
- 46731500.960 (5 vie / 5 valves - Multifilare / Multirow)
- 46731700.960 (7 vie / 7 valves - Multifilare / Multirow)
- 46734400.960 (4 vie / 4 valves - Atomizzatore / Orchard sprayers)
- 46736500.960 (5 vie / valves - SELEJET)
- 46736700.960 (7 vie / valves - SELEJET)

V2B21D x 2

46730000.011

46730000.300

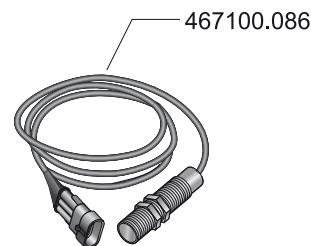

E000037

ESC0003

467005.510

467305.080

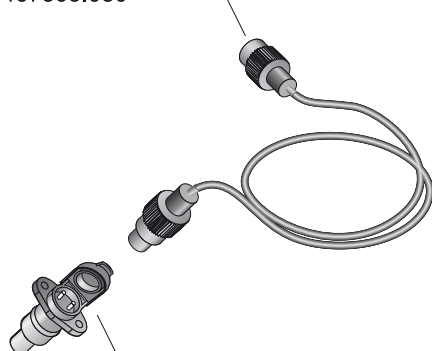

466001.010

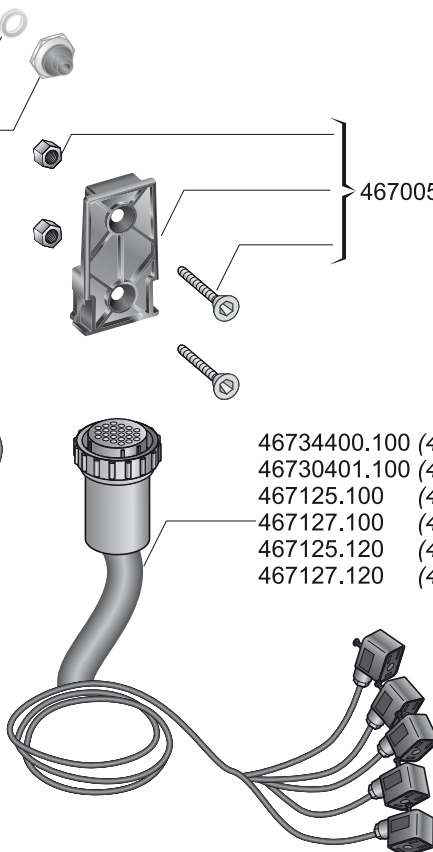

- 46734400.100 (46734401 4 vie / 4 valves, 4m)
- 46730401.100 (4673x401 4 vie / 4 valves, 6m)
- 467125.100 (4673x501 5 vie / 5 valves, 6m)
- 467127.100 (4673x701 7 vie / 7 valves, 6m)
- 467125.120 (4673x502 5 vie / 5 valves, 10m)
- 467127.120 (4673x702 7 vie / 7 valves, 10m)



PRODUCT PART NUMBERS

46718001 - 46718301 - 46718401 - 46718501 - 46718251 - 46718351 - 46718451 - 46718551 - 46718231 - 46718431

- 46718000.960 (G + P - Diserbo / Crop sprayers)
- 46718230.960 (2 vie, 2 valves - Atomizzatore / Orchard sprayers)
- 46718250.960 (2 vie, 2 valves - Multifilare / Multirow orchard sprayers)
- 46718300.960 (3 vie, 3 valves - Diserbo / Crop sprayers)
- 46718350.960 (3 vie, 3 valves - Multifilare / Multirow orchard sprayers)
- 46718400.960 (4 vie, 4 valves - Diserbo / Crop sprayers)
- 46718430.960 (4 vie, 4 valves - Atomizzatore / Orchard sprayers)
- 46718450.960 (4 vie, 4 valves - Multifilare / Multirow orchard sprayers)
- 46718500.960 (5 vie, 5 valves - Diserbo / Crop sprayers)
- 46718550.960 (5 vie, 5 valves - Multifilare / Multirow orchard sprayers)



E000037
ESC0003

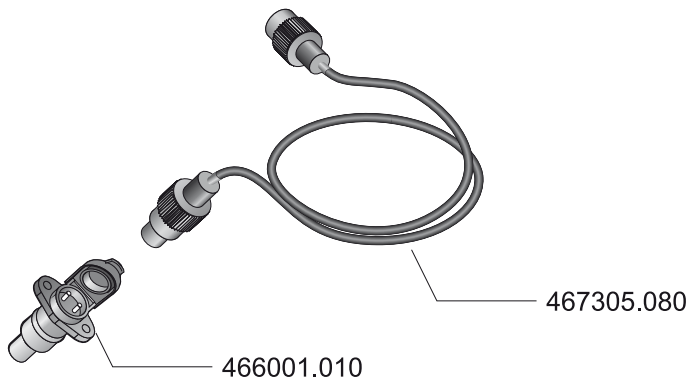

466001.010

467305.080

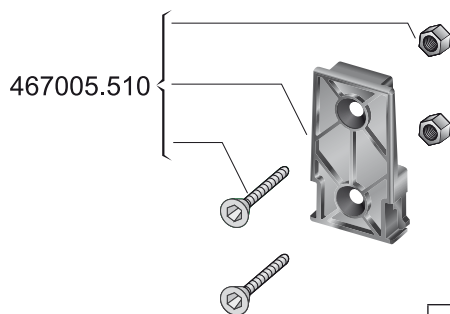

467005.510

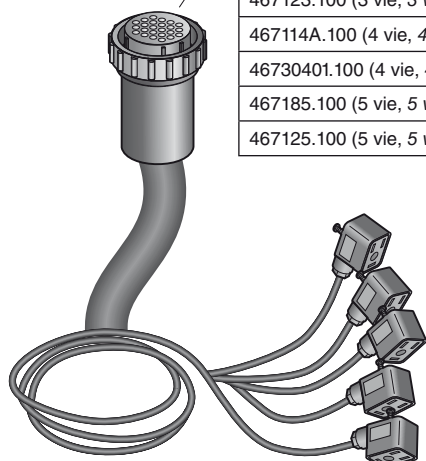

	Diserbo Crop sprayer	Atomizzatore Orchard sprayer	Multifilare Multirow sprayer
467180.100 (G + P - 6 m)	●		
467112A.100 (2 vie, 2 valves - 4 m)		●	●
467183.100 (3 vie, 3 valves - 6 m)	●		
467123.100 (3 vie, 3 valves - 6 m)			●
467114A.100 (4 vie, 4 valves - 4 m)		●	●
46730401.100 (4 vie, 4 valves - 6 m)	●		
467185.100 (5 vie, 5 valves - 6 m)	●		
467125.100 (5 vie, 5 valves - 6 m)			●

467100.086

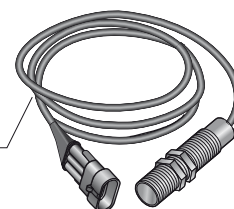

PRODUCT PART NUMBERS

46713201 - 46713401



46713200.960 (2 vie / valves)
46713400.960 (4 vie / valves)

E000037
ESC0003

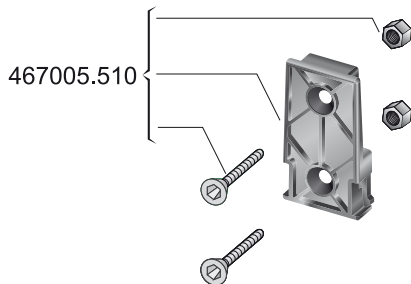

467005.510

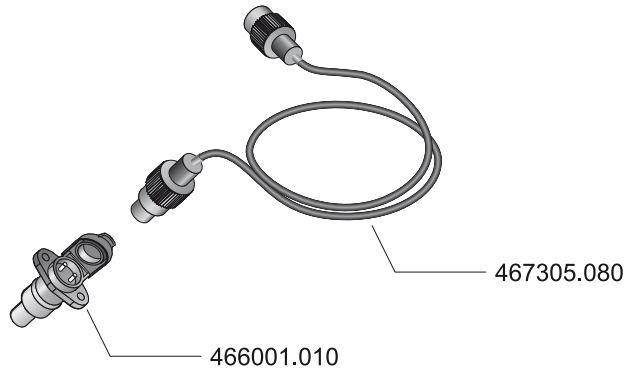

467305.080

466001.010

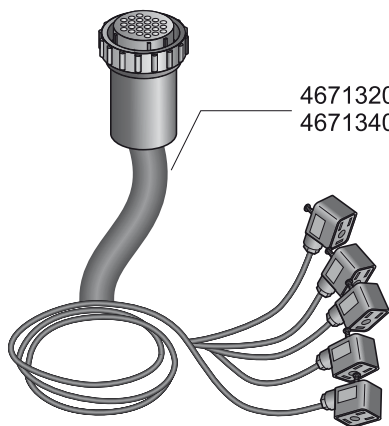

46713200.100 (2 vie / valves - 7,5 m)
46713400.100 (4 vie / 4 valves - 7,5 m)

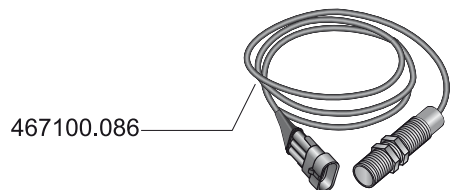

467100.086



PRODUCT PART NUMBERS

467120 - 467123 - 467125

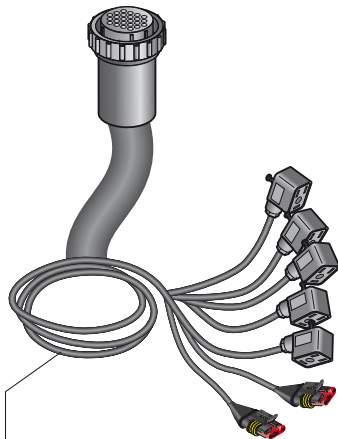
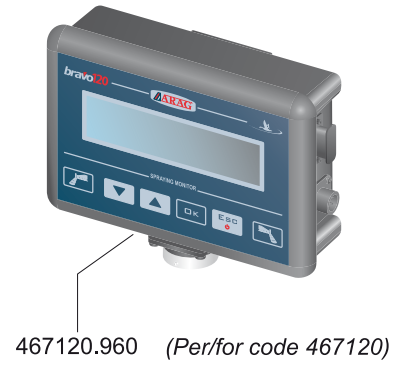
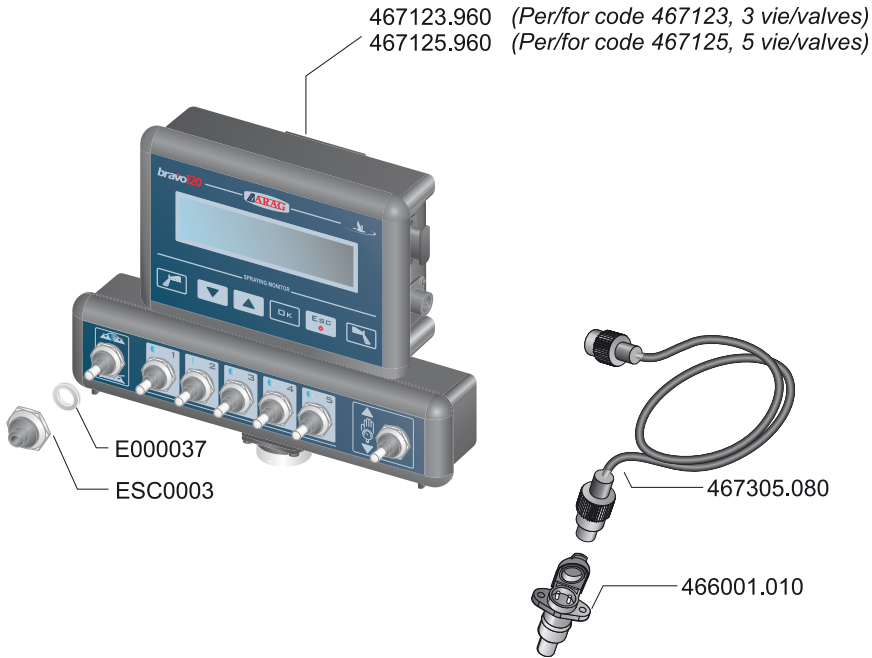

467123.100 (Per/for code 467123, 3 vie/valves - 6 m)
467125.100 (Per/for code 467125, 5 vie/valves - 6 m)

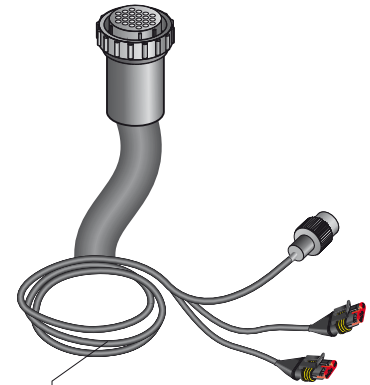
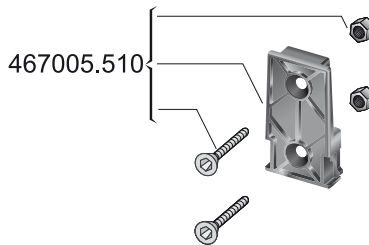

467120.100 (Per/for code 467120)



PRODUCT PART NUMBERS

467110 - 467113 - 467115 - 467110A - 467112A - 467114A

467112A.960 (Per/for code 467112A, 2 vie/valves)
 467114A.960 (Per/for code 467114A, 4 vie/valves)
 467113.960 (Per/for code 467113, 3 vie/valves)
 467115.960 (Per/for code 467115, 5 vie/valves)

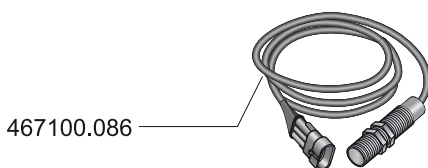
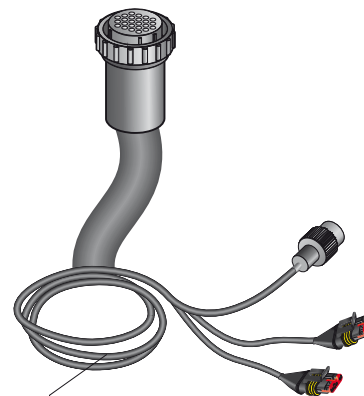
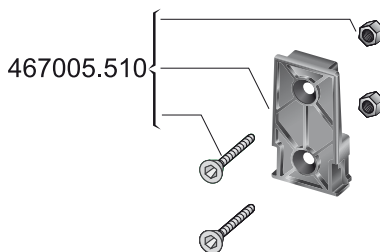
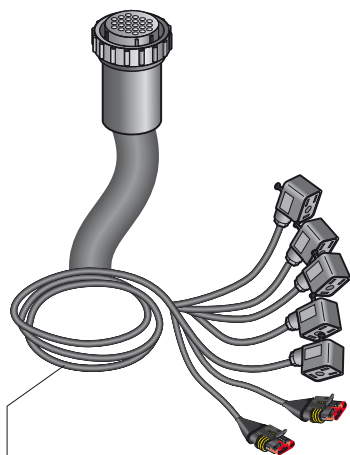
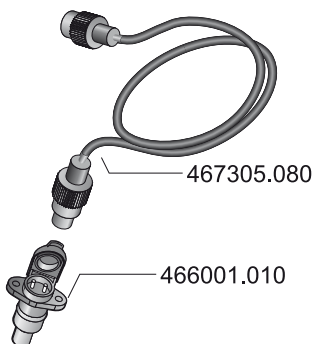



PRODUCT PART NUMBERS

4621Bxxxxx - 4622Bxxxxx

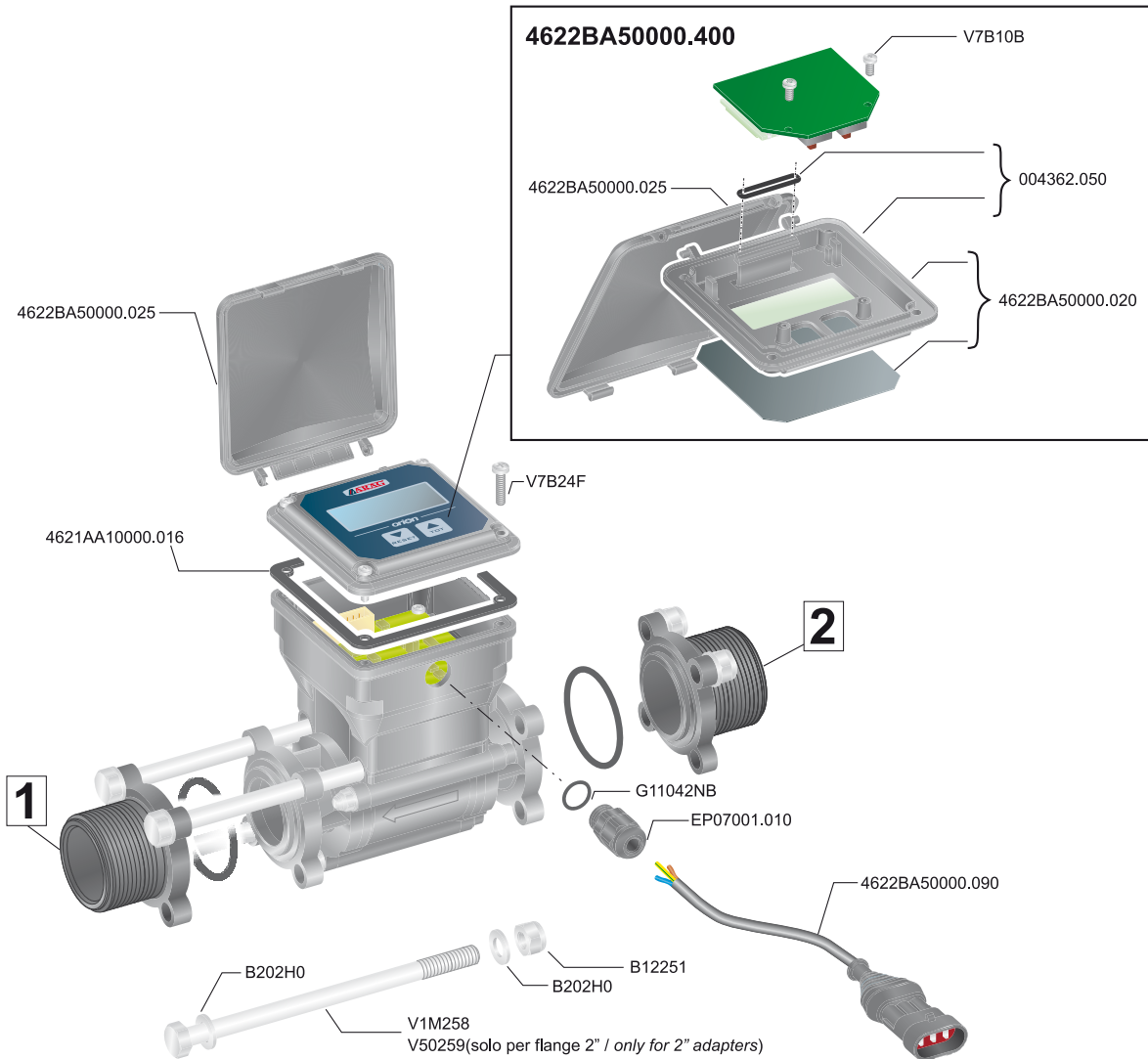

FLOW-METER CODE	1	2	CONNECTION	MATERIAL
4621BA01313	463000.130	463000.030	G 3/4 M	Nylon
4621BA03333	463000H.130	463000H.030	G 3/4 M	Brass
4621BA11313	463000.130	463000.030	G 3/4 M	Nylon
4621BA13333	463000H.130	463000H.030	G 3/4 M	Brass
4621BA21313	463000.130	463000.030	G 3/4 M	Nylon
4621BA23333	463000H.130	463000H.030	G 3/4 M	Brass
4621BA31414	463000.140	463000.040	G 1 M	Nylon
4621BA33434	463000H.140	463000H.040	G 1 M	Brass
4621BA41515	463000.150	463000.050	G 1 1/4 M	Nylon
4621BA43434	463000H.140	463000H.040	G 1 M	Brass
4622BA51616	473000.160	473000.060	G 1 1/2 M	Nylon
4622BA61616	473000.160	473000.060	G 1 1/2 M	Nylon
4622BA61717	473000.170	473000.070	G 2 M	Nylon
4621BA41414	463000.140	463000.040	G 1 M	Nylon

PRODUCT PART NUMBERS

4621AAxxxxx - 4622AAxxxxx

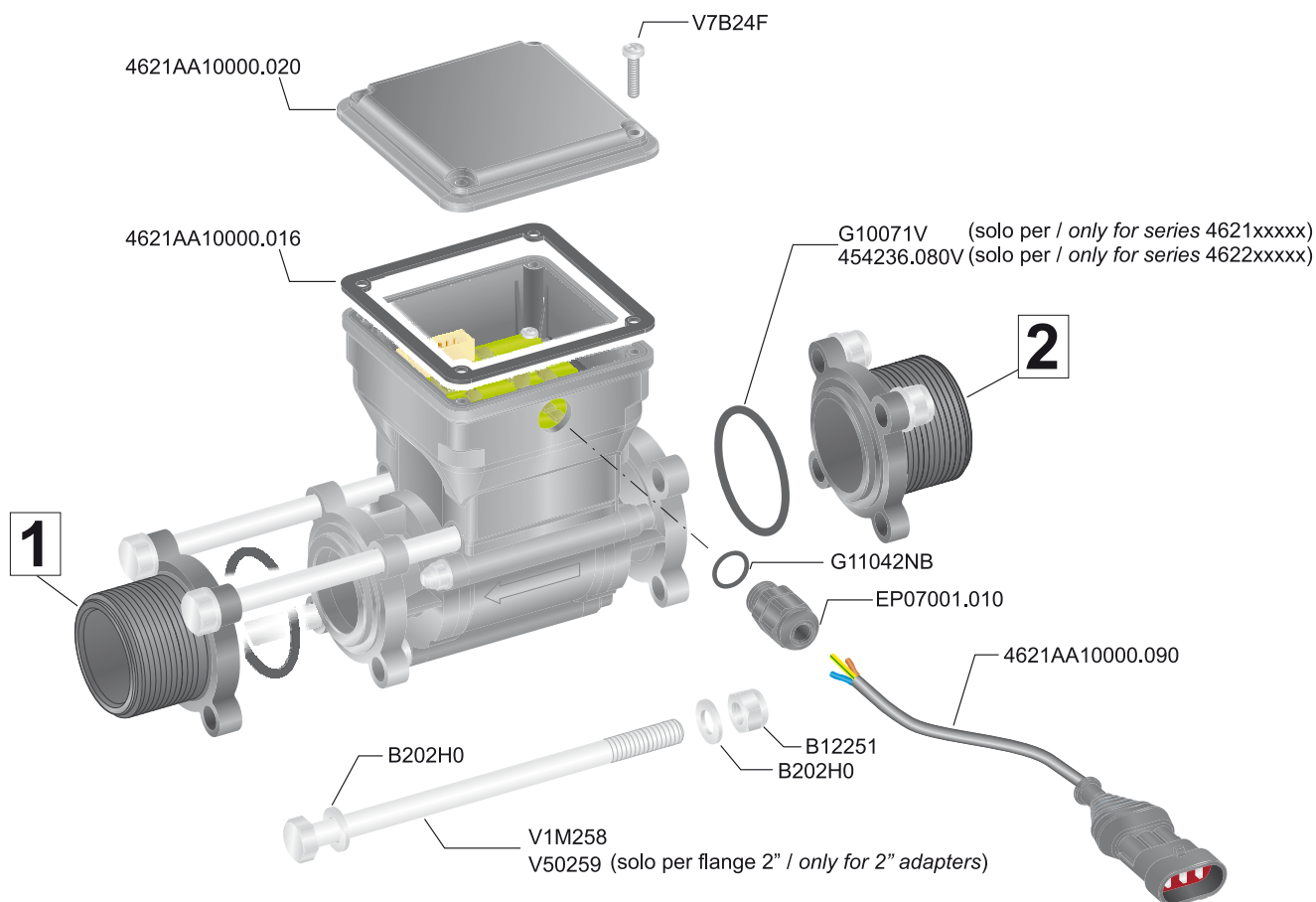

FLOW-METER CODE	1	2	CONNECTION	MATERIAL
4621AA01313	463000.130	463000.030	G 3/4 M	Nylon
4621AA03333	463000H.130	463000H.030	G 3/4 M	Brass
4621AA11313	463000.130	463000.030	G 3/4 M	Nylon
4621AA13333	463000H.130	463000H.030	G 3/4 M	Brass
4621AA21313	463000.130	463000.030	G 3/4 M	Nylon
4621AA23333	463000H.130	463000H.030	G 3/4 M	Brass
4621AA31414	463000.140	463000.040	G 1 M	Nylon
4621AA33434	463000H.140	463000H.040	G 1 M	Brass
4621AA41414	463000.140	463000.040	G 1 M	Nylon
4621AA41515	463000.150	463000.050	G 1 1/4 M	Nylon
4621AA43434	463000H.140	463000H.040	G 1 M	Brass
4622AA51515	473000.150	473000.050	G 1 1/4 M	Nylon
4622AA51616	473000.160	473000.060	G 1 1/2 M	Nylon
4622AA61616	473000.160	473000.060	G 1 1/2 M	Nylon
4622AA61717	473000.170	473000.070	G 2 M	Nylon

The **ARAG**® group



ITALY
ARAG srl
RUBIERA (RE)
Tel. +39 0522 622011
info@aragnet.com



UNITED KINGDOM
INTERNATIONAL SPRAY-JETS Ltd.
Ilkeston
Tel. +44 (0) 1159 444069
sales@internationalspray-jets.com



BRAZIL
AGROJET DO BRASIL
Pinhais
Tel. +55 41 3668-7020
agrojet@agrojetbrasil.com.br



BRAZIL
ARAG MT LTDA
RONDONÓPOLIS - MT
Tel. +55 66 3421-1001
aragmt@terra.com.br



ARGENTINA
AGROJET S.A.
ROSARIO - SANTA FE
Tel. +54 341 458-3838
info@agrojet.com.ar



ARAG srl - 42048 RUBIERA (RE) Italy
via Palladio, 5/A
Tel. +39 0522 622011
Fax +39 0522 628944
www.aragnet.com

Ufficio Commerciale Italia:
Tel. 0522 622036
Fax 0522 628840
vendite@aragnet.com

Export:
Tel. +39 0522 622010
Fax +39 0522 628944
export@aragnet.com



DC7001 - Rev.01 - 01/2009 INGLESE

